

Metal Sheet Products  
SOLUTIONS PROVIDER



# STEEL INTERTECH

บริษัท สตีล อินเตอร์เทค จำกัด (มหาชน)

รายงานประจำปี 2553  
ANNUAL REPORT 2010

## CONTENTS

---

Message from Chairman	2
Audit Committee Report	3
Message from Managing Director	4
Corporate Social Responsibility	5
Company Profile	6
Financial Highlight	7
Business Nature	9
Risk Factors	27
Shareholding Structure and Management	30
Board of Directors and Executives	32
Inter Transactions	51
Management Discussion and Analysis	53
Audit Report of Certificated Public Account	58
Financial Statement	59

---

**Message from Chairman**

The economy in 2010 was grown up from previous year, and trends in 2011 will lightly grow from year 2010 due to a world trade factors have recovered and the flow of funds of investment as well. However, the high unemployment in many countries such as the U.S. and EU as well as debt crisis in Europe, currency fluctuation risk including cutting the economic stimulating projects by its own government in many countries, these factors will put pressure on the recovery of world economy and also affect to financial market that has more risk of instable conditions. But the strong economic growth in developing countries is a key factor driving to recover. For the global financial situation, most central banks of many countries will raise interest rate gradually in order to maintain economic stability and control inflation. The world oil price situation is likely to increase. However, the most economic indicators had risen comparing to the same period in 2009. The direction of Thai economic growth in year 2011 has a force from expansion in year 2010 resulted continual growing. The increasing in the revenue base of consumers and overall economy such as official salary, minimum wage along with agriculturist income which is likely to improve from increasing of agricultural price level. But there are also risks factors from economic recovery which is still fragile, especially the recovery of the European Union and Japan are likely grew at a low level. The political situation may affect to the confidence of foreign investors to slow down investment in Thailand and be a major barrier to develop in other areas.

Although, the world and Thai economy in year 2011 are likely growing up due to vary parties, especially government has announced many economic stimulating projects. However, the company still have to operate its business carefully due to there is still a risk and uncertainty. The company focuses on effective cost management, customer credit analysis in order to avoid affecting liquidity management, inventory management with carefully including keep going on reduce operation cost, using existing resources in order to be maximum benefits, also enhance and improve more product quality. Hence, the company believes in transparency management in accordance with a Good Governance resulting the company able to be sustainable in changing circumstances. In addition, the company has the efficient internal controlling system and provided the training toward our employees and executives in order to build efficient personnel and bring the entire useful to develop organization, which maximizing the business value to all stakeholder as equitably.

Lastly, on behalf of the committee, I would like to express my sincere thanks to all parties concerned: shareholders, customers, business partners, financial institutions, mass media, analyst, local and foreign investors, our employees and management team who continually trust and support our company. Moreover, I trust the company has a good potential to expand its business and will continue further growth and hopefully, the company will be received support and encouragement to be keep steady going forward.



Dr. Suradej Chantranuruk

Chairman of the Board of Director

## Audit Committee Report

The Audit Committee of STEEL INTERTECH PUBLIC COMPANY LIMITED consists of 3 independent directors namely Dr. Suradej Chantranuruk as a Chairman, Mr. Numpon Ngunnumchoke and Mr. Lertchai Wongchaiyasit – as members of the Audit Committee as well as BK Audit and Consultant is an internal auditor.

The Audit Committee is authorized and responsible for reviewing the company's financial statements which include financial statement collation and accounting policies in accordance with generally accepted accounting principles, internal control system and risk management as proper and effective. In addition, to assure that the company is operating in good governance and comply with relevant law and regulations

In fiscal year 2010, the Audit Committee held 4 meetings, by inviting the concerned executives and internal auditor to discuss and evaluate the following agenda during the meetings:

1. Reviewed quarterly financial reports (three months basis) and the annual financial statements of the year 2010 to the Board of Director for consideration. The Audit committee had the opinion that the company's financial report conforms to generally accepted accounting principles.

2. Reviewed the company's internal control systems and specified the annual audit of the internal audit as well as considered quarter internal reports and recommended to the management to improve company's performance, enhancing with efficiency.

3. Reviewed the company's operations to ensure that it's complied with rules and regulations of Securities and Exchange Commission, Stock Exchange of Thailand in correlation with good governance.

4. Consider and choose S.K. and Accountant Services Co., Ltd. as the company's auditor in year 2010 and the next one year and also recommending on their fees to the board of directors. The Board of Director will then propose the same proposal to the Shareholders for approval.

During 2010, the economy slowdown resulted by the financial crisis in the United States at the end of year 2009, including amid uncertainty political situation which affect to the price volatility of raw materials that are difficult to expect as well. The currency fluctuation of Thai Baht was more likely to be uncertain due to the movement of foreign investors which were directly affected from our partner business such as, the slowdown in economy of the United State. The Audit Committee has emphasized in perform their duties carefully and independently as well as expressing opinions and recommendations in the report completely. The Audit Committee believed that the company adheres to operating in accordance with specified patterns. Moreover, the company emphasized financial report in accordance with generally accepted accounting principles, also has a proper and adequate internal control systems through comply with laws and regulations of the SET as well as maintain its good corporate governance.

Dr. Suradej Chantranuruk



Chairman of the Audit Committee

**Message from Managing Director**

Earning in fiscal year 2010 ending December 31, 2010 is considered the company has developed into a better direction, which is grown up both of in terms of revenue and net profit. The total revenues was THB 311 millions, representing growth rate in the fiscal year up from 6 percent and net profit was THB 8.9 millions increasing from previous fiscal year 140 percent. Besides, closely cost control management made the net profit increased to double from last year. Although the business operating in the past year was not very difficult compared to the previous year, but there were still the risk factors from surrounding. The company must operate its business on the principle with careful, we believe that make the business has been growing steadily and continued sustainability. In order to be a quality organization to innovate the quality product along with paying attention to social and environment to maintain the benefit of overall stakeholders. In addition, the company adheres in management with the Good Corporate Governance and business ethics which these practices are clearly defined.

Overall steel situation in year 2010 comparing to the same period of last year, showed that production increased by 17.10 percent, domestic demand increased 44.33 percent due to demand of industries including total value and volume of exports increased at 21.52 percent and 16.10 percent, respectively. As a result of increasing of other semi-finished steel products at 203.32 percent, seamless steel pipes increased up 118.11 percent and cold-rolled stainless steel sheet also increased to 99.17 percent. In year 2011, steel industry is expected to grow continuously due to both the construction and manufacturing sectors expected to grow. Despite, a global economic outlook is subject to currency fluctuations. The construction sector still has new opportunities from private investment, especially investment in infrastructure in year 2010 which already bid and prepared construction projects. Therefore, the operation of the company must have the proper strategy for economy and closely monitor in order to amount of work and the performance of the company according to its goals.

Behind the success of the company is caused by the confidence and support well all along. I would like to express my sincere thanks to all parties concerned: shareholders, business partners, customers, financial institutions, mass media as well as public and private organizations including all executives and employees who put the highest effort in order to be leader in metal roof market and steel structure under the quality policy “delivery of quality products to our customers with continuous improvement and highest customer satisfaction”, in order to earns trusted from customers under the ROLLFORM brand.



Mr. Prasit Ounvorawong  
Managing Director

## Corporate Social Responsibility

With consciousness of being one part of Thai society, Steel Intertech Public Company Limited has concerned to the Corporate Social Responsibility (CSR) which is an important in operation. Therefore, the company also operates its business under ethical principles and good governance along with care and looking after society and environment bring to sustainable business development. Also continuously provides support for public participation as well as beneficial activities to society.

In past 2010 year, the company held CSR activities in organization, aimed to create and help society as following;

1. Scholarship program for grade 1-6 students at Sri Suk Vittaya School where is located in Don Chom Phoo Sub-District, Non Soong District, Nakornratchasrimam, on August 21,2010.
2. Donated metal sheet for flood victims through the Channel 9 MCOT on November 24, 2010.
3. A multipurpose roof building project at Sirimongkol temple school, Samutsakorn, on December 14,2010.
4. Used paper recycling project for foundation for the blind in Thailand under the royal patronage of H.M. the Queen.

In addition, the above activities resulted to mutual spirit between employees and raising to awareness in corporate social responsibility to all employees.

## 1. Company Profile

<b>Company Name:</b>	Steel Intertech Public Company Limited
<b>Type of Business:</b>	Manufacture ,distribution and installation of Roll Forming metal sheet including other related roof and wall cladding
<b>Head Office:</b>	8/88 Moo 12, Rachathewa, Bangplee, Samutprakarn 10540
<b>Factory Location:</b>	8 Moo 15, Bangplee Yai, Bangplee, Samutprakarn 10540
<b>Registration No.:</b>	0107574800137
<b>Home Page :</b>	www.steelintertech.com
<b>Telephone:</b>	0-2750-2380
<b>Facimile:</b>	0-2750-2394
<b>Common Share:</b>	500,000,000 Shares
<b>Par Value:</b>	1 baht
<b>Paid-up Capital :</b>	50,000,000 baht
<b>Register at :</b>	Thailand Securities Depository Co.,Ltd. The Stock Exchange of Thailand Building, 4 <sup>th</sup> and 7 <sup>th</sup> Fl. 62 Rachadapisek Rd., Klongtoey, Bangkok 10110 Telephone : 0-2229-2800 Fax : 0-2359-1259
<b>Independent Auditors :</b>	Mr. Ampol Chamnongwat, CPA No. 4663 or Ms. Wanraya Puttasatien, CPA No. 4387 or Mr. Naris Saowalagsakul, CPA No. 5369 S.K. Accountant Services Co., Ltd. Phayathai Plaza Building, 14 <sup>th</sup> Floor 128/151 Phayathai Rd., Thungphayathai, Ratchathewi, Bangkok 10400 Telephone : 0-2217-6464 Fax : 0-2215-4772

## 2. Financial Highlights

### Consolidated Income Statement for the Year Ended December 31 (in thousand baht)

	2008	2009	2010
Sales Revenue	360,121.22	293,126.68	311,435.36
Total Revenue	363,374.54	295,775.90	316,254.44
Net Profit (Loss)	20,167.74	3,703.75	8,973.41
Earning (Loss) per share (Baht)	0.40	0.07	0.18

### Consolidated Balance for the Year Ended December 31 (in thousand baht)

	2008	2009	2010
Total Assets	203,455.42	192,042.05	163,140.34
Total Liabilities	101,993.44	105,374.10	69,998.98
Shareholder's equity	101,461.98	86,667.95	93,141.36
Issued and Paid-up share capital	50,000.00	50,000.00	50,000.00

Items		2008	2009	2010
<b>Liquidity Ratio</b>				
Liquidity Ratio	(Times)	1.33	1.16	1.27
Quick Ratio	(Times)	0.72	0.67	0.88
Cash Flow Ratio	(Times)	0.15	0.14	0.52
Account Receivable Turnover	(Times)	6.04	4.50	4.87
Average Collection Period	(Days)	60	80	74
Inventory Turnover	(Times)	8.16	5.63	8.33
Average Sales Period	(Days)	44	64	43
Account Payable Turnover	(Times)	5.06	4.73	5.54
Payment Period	(Days)	71	76	65
Cash Cycle	(Days)	33	68	52
<b>Profitability Ratio</b>				
Gross Profit	(%)	18.05 %	15.13 %	18.04%
Profit from Operation	(%)	7.81 %	2.39%	4.49%
Return on Cash Flow	(%)	43.22 %	173.42 %	286.18%
Net Income	(%)	5.55 %	1.25 %	2.84%
Return on Equity	(%)	20.40 %	3.94 %	9.98%
<b>Efficiency Ratio</b>				
Return on Total Assets	(%)	10.34 %	1.87 %	5.05%
Return on Fixed Assets	(%)	32.80 %	14.15%	21.14%
Total Assets Turnover	(Times)	1.86	1.50	1.78
<b>Financial Policy Ratio</b>				
Debt-to-Equity	(Times)	1.01	1.22	0.75
Times Interest Earned	(Times)	16.01	13.91	43.78
Times Burden Covered	(Times)	0.64	0.39	1.16
Dividend Ratio	(%)	229.49%	138.97%	N.A.

### 3. Business Nature

#### 3.1 Company Background and Development

Steel Intertech Public Company Limited (Company) was initially incorporated on August 6, 1993 under the name of Thitipat Serpoint Company Limited, principally engaged in sole distribution of roll forming metal sheet products. In December 8, 1995 it was renamed to Steel Intertech Public Company Limited (Company). In the following year of 1996, Mr.Prasit Ounvorawong, holding a position of Vice President of the company acquired shares from the major shareholder and assumed the role of Managing Director. Since then, the company has expanded its operation and established a Roll Forming Plant to manufacture Roll Forming and diversified its products to manufacture and distribute walls, spandrels, louvers, truss and other supplementary. From the restructuring of management as well as a well plan marketing strategy directed by Mr.Prasit Ounvorawong, the company has been continuously prosperous with profit and business expansion.

#### Major Chang and Development

August 6,1993	“Thitipat Serpoint Company Limited” was established with initial registered capital of 2 million baht for 20,000 shares at 100 baht par value, situated at 331-332 Moo 3, Suksawat 29 Rd., Ratburana, Bangkok 10400
December 8,1994	Renamed to Steel Intertech Company Limited
May 28,1995	Registered capital was increased from 2 millions baht to 2.4 million baht, with the objective of working capital
September 15,1995	Registered capital was increased from 2.4 million baht to 5.6 million baht, with the objective of working capital. Mr.Prasit Ounvorawong’s shareholding group (consisted of Mr.Prasit Ounvorawong, Mr.Thepsak Ounpitipongsa and Mr.Nat Whangmahaporn) collectively owned 38.39% of total shares.
November 10, 1995	“ROLLFORM” was registered as official brand name, which has been used on roll forming metal sheet products until present.
June 6,1997	Mr.Prasit Ounvorawong’s shareholding group (consisted of Mr.Prasit Ounvorawong, Mr.Thepsak Ounpitipongsa, Mr.Nat Whangmahaporn and Mrs. Kasemsri Wannarote) acquired further shares from existing shareholders, increasing the group’s shareholding ratio to 72.32%.
October 27, 1999	Registered capital was increased from 5.6 millions baht to 20.5 million baht, with the objective of

investment in roll form machinery and new plant construction.

October 29, 1999	Steel Intercon Company Limited was incorporated as a subsidiary to be engaged in installation services for roll forming metal sheet products. Steel Intercon registered capital of 1 million baht, 10,000 shares at 100 baht par value per share. The company owned 30% of shares in Steel Intercon. The main objective of established Steel Intercon is to separate products sales from installation services, which would allow the withholding tax to be paid only on the services.
September 13,2001	Head office and Plant were relocated to the present address of No. 8 Moo 15, Soi Kingkaew 11, Bangplee-yai, Bangplee, Samutprakarn 10540.
August 31,2004	Registered capital was increased from 20.5 million baht to 35.0 million baht, issued common shares of 145,000 shares, offered to the existed shareholders as per shareholding ratio, with the objective of capital.
September 30,2004	Cash investment of Steel Intercon at book value of 208 baht per share or in total of 624,000 baht was sold to Mr. Nat Whangmahaporn, a shareholder, for purpose of business dissolution (see details in transactions: part2 page 51). All pending contract installation projects were transferred, and all joint operations with this subsidiary were discontinued. The organizational restructure was aimed to reduce complexity of consolidated financial statements, reduced expenses incurred from financial statements auditing and increasing business transparency.
February 11,2005	Attainment of ISO 9001:2000 Certification for “Manufacture of Metal Sheet for Construction” from BVQI (Thailand) Ltd.
March 16,2005	Registered to be Public Company and announced share value of 1 baht at par.
May 6,2005	Registered capital was increased from 35.0 million baht to 50.0 million baht by issued 15 million common shares offered to public, and registered them on Thailand’s Market for Alternative Investment (MAI) with the permit no. Bor. 897/2548 on November 30, 2005. Stocks trading was launch on December 20, 2005
2006	Invested in roll form machinery – high curve mode (High-rip: V-750BL), with capacity of 3,400 tons per year or 600,000 sq. m. and high tensile purlin machinery for C and Z beam, with capacity of 2,000 tons per year. At the end of Q4/2006, expansion of plant area, expected to be completed in Q1/2007 to increase inventory space and to support sales growth in the future.

- 2007                      Company expanded factory area in Q2/2007 that increasing more space of storage to support the expansion of its sales in the future. The new profile “High rib” V-750 has been begun to manufacture in 3<sup>rd</sup> quarter of 2007 as well as the new office was built on the land next to the factory, expected to finish on the beginning of 2008.
- 2008                      The new office was built on the land plot next to existing factory, officially started opening since January 2008, by increasing more utility area and enable to support expanding growth in the future.
- 2009                      The company has begun providing new sources of raw materials that be cheaper in order to support to shrinking of market due to affected from the subprime mortgage segment of the United States in the end of year 2008.
- 2010                      In 2010, the Board of Director approved the merger with Solar Power Company Limited, which is operating in energy business as well as benefit in term of solar power plant in the future.

### **3.2 Overview of company’s business operation**

The generally economic situation in year 2010, Thailand still faced many problems such as ; uncertainty politic as well as Thai baht was strong in middle year, these directly affected to export and import section. The unrest situation in the 3 southern provinces of the country has been still occurred now affected to overall economic situation in year 2010 was under in uncertain condition. The private section has begun investing in long-term assets resulted from rapidly strong of Thai baht effect to low cost of long-term investment, resulting the company’s turnover was satisfactory.

The company operates as manufacturer and distributor of building materials such as roll form roof and wall cladding of Aluzinc coated metal sheet and pre-painted COLORBOND as well as spandrel, shades, fence, louver, etc. These materials have the quality to prevent water leakage and erosion resistance, long life and corrosion provide warranty up to 30 years. The company has earning ratio of 90% of the total income from roll form coated roofing metal sheet. Additional, the company also has C&Z purlins which are produced by roll-forming from high tensile steel of G450 coated with zinc for rust protection. Both are suitable for steel structure for roofing or wall panel. The material is lighter, comparing to the one made from black steel. The dominant quality is light weight, quick to install by using screw instead of welding. The production of roll form coated roofing metal sheet High-rib. The high rib design is popular amongst Japanese industries. The company believes that the high rib profile will be competitive among Japanese factories in the local market because of the lower in price and the being amongst the early market entry, the company can gain greater market share than the late market entry. This also leads to the greater awareness of Steel Intertech amongst customers operating in Thailand. In additional, the company also offers other related building products, like pre-fabricated steel structure, and transparency roofing sheet, insulations, etc. The company’s customer base are industrial plants, both newly built and those under renovation of the roof. The company also sells through contractors, distributing agent and directly to project owners.

The company manufactures and distributes the roll form coated metal sheet and purlin made from high tensile steel C&Z purlins under the “ROLLFORM” trade mark. In 2005, the company was granted by Blue Scope Steel (Thailand) Co., Ltd. the use of logo “Steel Supplied by BlueScope Steel”. This is for the customers to have confidence in the materials with the same quality standard.

The operating in business in year 2010 increased from the previous year due to recovering of world trade factors and the flow of funds of investment as well. However, the company has to operate business with carefully due to uncertainty in political situation that may effect to the confidence of foreign investors to delay investing in Thailand which is a major barrier to development in other areas as well as facing material price fluctuation. In addition, the company tried to put effort to maintain the customer by focusing on services and closely provide the solution in order not to lose a chance for sailing, stimulating rapidly close the deal.

The direction of business development, the company focuses on the wide scope marketing, with introduction of new products concerned to develop its business as the Solution Provider, by seeking the new alliances via the presentation of new giant projects. The company is adjusted the distribution channel from selling products with installation via contractors. The company still maintains the main customers to distribute products via dealer. Currently there are 48 distribution agents, covering Bangkok and other areas. In the year 2010, the ratio of the distribution is 59 percent of all year sales increasing from year 2009 at 49.40 percent and the distribution via dealer ratio is 41 percent of all year sales.

In the long run, the company aims to develop to “One Stop Service” starting with negotiation with alliances both local and overseas. This is to support the joint business and to support the company in term of technology transfer in civil engineering design and architect, leading to the One Stop service in the future.

### 3.3 Revenue Structure

Revenue structure during fiscal year 2008-2010 are as follow;

Revenue Structure	Financial Statement					
	2008		2009		2010	
	Valued (Thousand Baht)	%	Valued (Thousand Baht)	%	Valued (Thousand Baht)	%
1. Revenues from Sales	223,173.80	61.42	148,316.25	50.14	145,105.14	45.88
2. Sales & Installation Services	136,947.41	37.69	144,810.43	48.96	166,330.22	52.59
3. Installation Services	-	-	-	-	-	-
4. Other Revenues	3,253.32	0.90	2,649.22	0.90	4,819.07	1.52
<b>Total Revenues</b>	<b>363,374.53</b>	<b>100.00</b>	<b>295,775.90</b>	<b>100.00</b>	<b>316,254.44</b>	<b>100.00</b>

### 3.4 Business Goals

Throughout our 16 years over presence in the industry, we have adopted business policy to be one of the leaders in the manufacturer, distribution, and installation of Aluzinc-coated roll forming metal sheet products, which are under the quality policy, **“Steel Intertech Public Company Limited is committed to delivery of quality and standard products to our customers with continuous improvement and highest customer satisfaction basis”**. Our business goal is **to increase market share in roofing material segment from 3% in 2004 to 8% by 2012**, which will be achieved through the deployment of the following strategies;





- (1) Focusing on product development by introducing new roll form profile and new product e.g. high tensile galvanized steel purlin, C and Z channel – a complimentary product to our core products, to provide fast and fully integrated customer service.
- (2) Developing from a single product sales presentation (Product Selling), to cluster products presentation to customers with integrated functionality in response to needs of project (Concept Selling). This approach enables our customers to gain maximized benefit from each purchase and simultaneously carves more market share for other products e.g. high tensile galvanized steel purlins and truss, with ultimate business development toward “Solution Provider”
- (3) Customer base Expansion: Particularly among Japanese end users who have been more receptive to Australian standard metal sheet products, by offered their preferred profile of high rip roll formed roof and wall cladding.
- (4) Continue improvement in Manufacturing: manufacturing efficiency is continuously improved with full compliance to ISO 9001: 2008 requirements. Improvement in management performance and managing our workforce through regular training. Safe workspace is maintained to ensure occupational health and safety favorable to work operations.
- (5) Focusing on private sector; the company has attained roofing steel sheet certification which is certified by T.I.S in the middle year 2009, enhancing a potential of its product to a standard that is widely accepted as well as expansion to the new customer in the future.

**3.5 Our core business classified by Product Line**

**3.5.1. Products and Services**

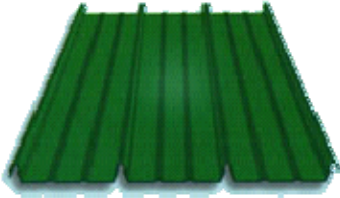
**3.5.1.1 Roll Forming Metal Sheet**

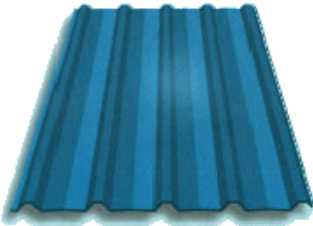
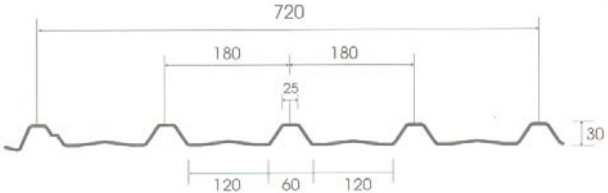
Steel Intertech Public Company Limited engages in manufacture and distribution of building material with specialization and expertise in roll forming metal sheet products, which are mainly roofing materials. Available roll formed profiles are as follow:

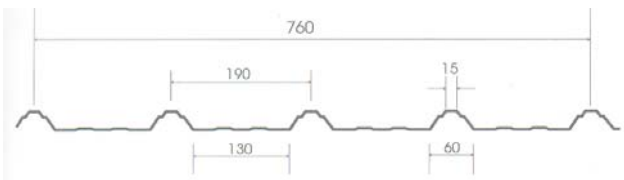
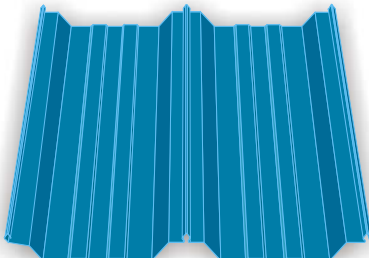
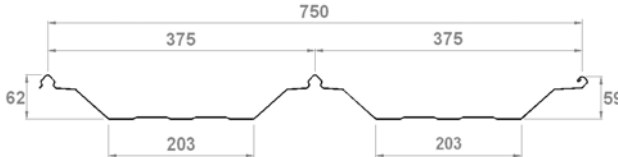
Model	Roll Form	Size (m.m.)
LOCK RIB V-680 BLH		
SAFE RIB S-720 B, S-720 BH		
ECON RIB E-760 B		
ROLL RIB V-750BL		

Apart from the above mentioned 4 profiles, we can also offering other profile specified by customers by acquire on loan machinery from our business alliance. However, the company is not regularly engaged to produce other profile. The case will be considered, based on order quantity and operation metal sheet.

In addition to its main application as roofing material, roll form can also be applied as building supplement materials e.g. wall, spandrel, fence, and louver. All of which, are available in various sizes and profile to meet customers' needs.

Roll forming metal sheet are leakage proof and heat resistance, making them ideal for roofing application in tropical Thailand. They also provide efficient light and heat reflection, hence, lowering the interior temperature in comparison with other conventional roof tiles. Its high protection against erosion allows it to stand well in hard erosive environment. Being light weight requires less supporting structures, therefore leads to saving on structural cost and installation time. Roll forming metal sheet can be freely formed into curved shape, thus allowing possible design variety and enhancing building elegance. Roll forming metal sheet products are made from durable material which carry a maximum warranty up to 30 years, four times higher than normal zinc coated sheet.

**3.5.1.2 High Tensile Galvanized Steel Purlins**

Apart from the Company's roll-formed metal sheet for roof and wall cladding, in 2006 the company also expands the product to include high tensile galvanized steel purlin. C and Z channel are made of zinc coated high tensile metal (G450), which are suitable for both roof supporting structure and wall supporting structure. Their weight is lighter than the normal beams. The parts are assembled by bolt and knots.

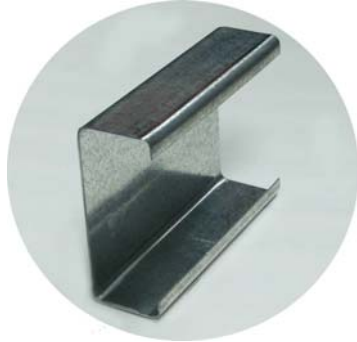
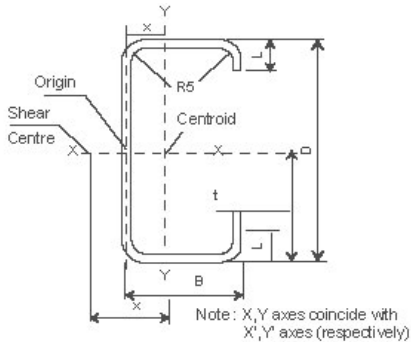
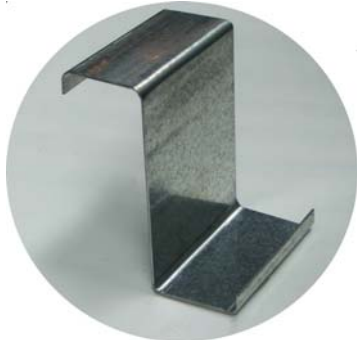
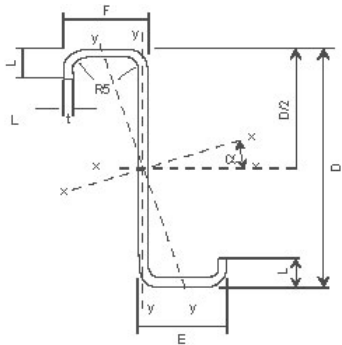
<b>Type of Purlins</b>	<b>Profile of Purlins</b>	
C Channel		
Z Channel		

Roll formed metal sheet and high tensile purlins “C” and “Z” channels are distributed under brand name “ROLLFORM” together with emblem “Steel Supplied by BlueScope Steel” of Blue Scope Steel, who is the company’s major supplier, to enhance the customer awareness of quality materials of international standard being used for our products.

### Classification and Property of Metal Sheet

Roll formed metal sheet products use material of different classification; each has different technical property and therefore different warranty period. The materials come in 2 major classifications.

#### 1) Pre-coated Metal Sheet with Zinc/Aluminum alloy coating (Zincalume)

Manufactured from Cold rolled sheet coated with Zincalume, a composition of 55% aluminum, 43.5% zinc and 1.5% silicon, Aluminum provides protection against corrosion from chemical reaction between air and metal. Zinc provides protection against corrosion at cutting edges and scratched marks. These protection properties provide superior durability, company to ordinary zinc-coated metal sheet in the market.

#### Illustration: Coating Layer of Metal Sheet with Zinc/Aluminum alloy coating (Zincalume)

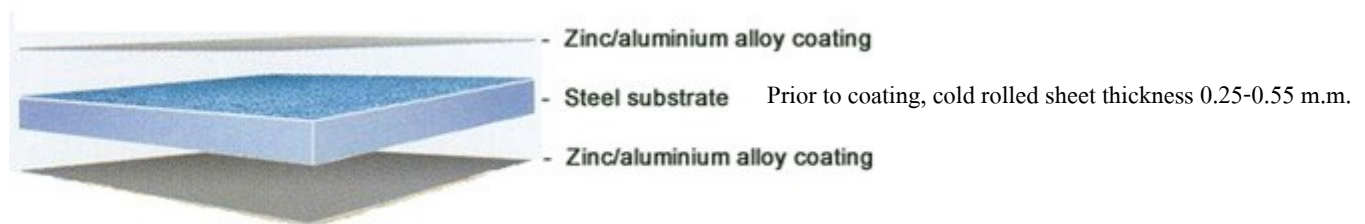

#### Classification of Zincalume Coating

Class of Material	Minimum Coating (Gram/ M <sup>2</sup> )	Warranty period
Zacs RW 70	70	5 years
Zacs RW 100	100	10 years
ZINCALUME <sup>®</sup>	150	20 years

#### 2) Pre-painted Metal Sheet (Color bond)

Pre-coated metal sheets (Zincalume) are further processed with layer of primer and paint. A special primer is applied to promote bonding between metal surface and color coating to prevent discoloration and delamination of paint layer. The next layer is an anti-corrosion layer, followed by high quality color on top. COLORBOND metal sheet provide superior corrosion resistant than other class of material. A range of more than 14 colors are available to meet customer’s requirement

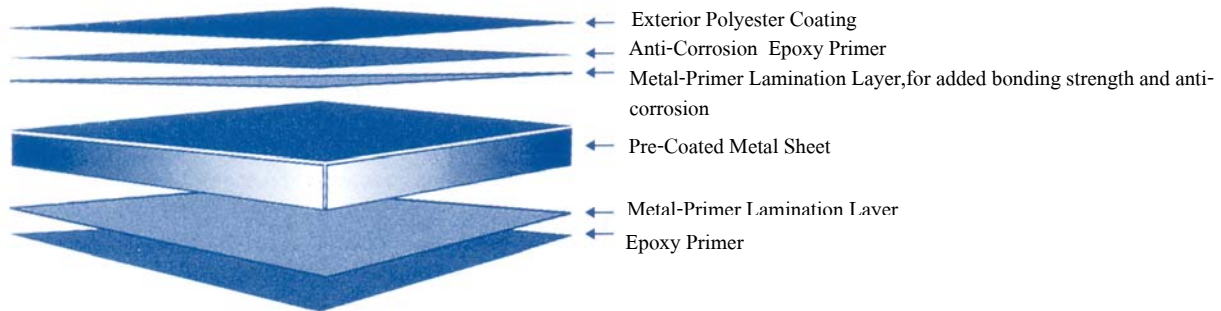
**Illustration: Coating Layer of Roll Forming Metal Sheet with COLORBOND**

Remarks: For Clean COLORBOND<sup>®</sup>, additional Polyester coating is provided on reversed side to increase durability and elegance.

**Classification of Pre-painted Metal Sheet**

Class of material	Pre-Coated Sheets	Warranty Period
P-Zacs SC 70	Zacs RW 70	10 years
P-Zacs RW 100	Zacs RW 100	20 years
Clean COLORBOND <sup>®</sup>	ZINCALUME <sup>®</sup>	30 years warranty against corrosion 10 years warranty against discoloration 5 years warranty against dust adhesion

**3.5.1.3 Other Products**

The company also distributes other building material complementary to the core products to offer to customers fully integrated services.

**1) Skylight: Translucent Roofing Sheet**

The company is a distributor of SKYLIGHT translucent roofing sheet suitable for both air-conditioned and non-air conditioned building that require natural sunlight.

**2) Complementary Products**

In order to promote ourselves as a fully integrated distributor, the company also supplies complementary products such as insulation material, bolt, screw etc., which complement the company's core products.

**3) Pre-Engineered Building (PEB)**

The company is a distributor of Pre-Engineered building (PEB) which is the latest innovation designed by professional engineer who has high experience. The PEB are designed following in customer needs and materials are

ordered as per international standard. The PEBs are delivered to all plants as set and each part of fabrics are designed by seizing with anchor bolts.

### **3.6 Marketing and Competition**

#### **3.6.1 Marketing Strategy**

##### **Brand Strategy**

The company is amongst leading manufacturer and distributor of Roll formed pre-coated and pre-painted roof and wall cladding metal sheet in Thailand, where market is very competitive. To differentiate the company's product and image, band "ROLLFORM" has played a significance role along with emblem "Steel Supplied by BlueScope Steel" owned by our raw material supplier. The policy is to increase customer awareness on the ROLLFORM product, manufactured from raw materials of internationally recognized standard.

##### **Distribution Network Strategy**

The company has boosted its sales through dealers' sales network. At the present, there are over 48 dealers covering both in Bangkok and other regions. Through this network, the company distributes its products, such through dealership network contributed more than 41% of total sales in 2010. The dealership network also provides sources of market intelligence and feedback which help the company to adjust its competitive strategy.

##### **Concept Selling Strategy and Solution Provider**

The company broadcasts its market by introducing new products such as "C" and "Z" Purlins in 2006, which are manufactured from zinc coated high tensile metal (G450). Its distinctive feature is light weight and ease of installation, and contributed toward the company's aspiration to become a "Solution Provider".

Besides, the new products "C" and "Z" purlins, the company also introduces a new roll forming profile, called "High Rib", which is very popular among Japanese industrial. This provides the company with an opportunity to enter into Japanese market. We believed that with new product at competitive price, the company will be able to expand our customer base amongst Japanese industry in Thailand.

##### **Efficiency & Customer satisfaction Strategy**

The company focuses on providing on time installation service and product delivery in response to our customer needs. Our roll formed metal sheet of pre-coated steel requires not more than 15 days for delivery and installation after order confirmation. For special request, the company tries to meet our customers' of shorter delivery timeframe in order to cultivate long-term business relationship. Upon project completion, or customer satisfaction survey is conducted in order to provide feedback for operations improvement and maximize customer satisfaction.

### **Advertising strategy**

The company adopts integrated marketing communication for advertising strategy, which features the using of combine marketing media and channels to create product awareness amount targeted end users. This strategy includes participation in public exhibition in order to reach the main target with concept as “Solution Provider”. The company launches the new products “C and Z purlins” through print advertisement, in Builder News Magazine. For direct mail campaign, the company dispatched catalog to introduce the company’s products to target industrial customers.

### **3.6.2 Targeted End Users and Distribution Channels**

#### **Targeted End users**

Target end users includes the small and medium industrial enterprises, both new set up as well as those undertaking renovation requiring refurbishing work on building structure and roof cladding. Industrial customers account for 95% of overall customer base. The company’s product reaches market/end users through 3 principle channels which are categorized into 3 customer groups as follow:

**(1) Contractor:** is primarily our targeted customer. In construction business, contractors directly deal with project owners and subcontract out to different sub-contractor. We are amongst subcontractors for roof and wall cladding. Nature of project varies from new industrial plant to renovation works on existing plants.

Since the major portion of our sales revenue is from building contractors, the risk of uncollected payment need to be well managed. Pre-sales analysis is conducted review contractor’s performance and financial status along with status of the project owner with information from Business Online Public Company Limited and from business alliance. A 30% advance is the company’s standard term. In case of order cancellation, the advance payment will be considered to discount to the next customer whose order matched the manufactured products. Our standard payment term stipulates a further 40% collection upon delivery. For most projects, 20% payment collection is undercutting upon completion of the installation. And only 10-30% left at the end upon project handover. For new customer, the company will request cheque for payment or letter of credit to reduce risk of uncollection.

The company plans to broader our customer base to cover Japanese end users through major contactors who have been dealing with Japanese industrial enterprises.

**(2) Dealer:** We distribute roll form metal sheet products and all other complementary products through our dealers, who make direct contacts with customers and provide installation service. The company conducts business with dealers on the same basis as we treat customers. Pricing and term to each dealer is based on purchase volume and order regularity. Appointment of dealers is based on business performance criteria such as efficient customer service, installation workmanship and active market penetration. Dealership network contributes toward the company’s sales to nationwide basis and mostly account for small to medium scale projects.

**(3) Project Owner:** Most of the project owners, contact us directly to renovate their plants to improve the building structure or replace roof tiles, or to expand their plant facilities, with intention to use our products. For these project owners, we devise the same risk management strategy for our trade account receivables in the same way we do for contractors. We plan to enhance sales volume through solution provider approach, which features integrated functionality of our core products, which are roofing material, high tensile steel purlins and supplementary products e.g. truss, insulation, skylight and etc. We concentrated on building structure that allows maximum utilization on the combination of our product range. We also provide service in connect with roofing renovation on contractual agreement basis to provide our customers with faster, more convenient yet innovative roofing solutions for either existing or new plant facilities.

### **Distribution Channels**

We apply direct sale strategy for product distribution through contractor and project owners. Well-trained and informative sale team is responsible for project presentation to architects and major contractors, including quotation and deal closing. In 2010, our marketing workforce dedicated for project sale, consisted of 7 well trained personnel. Aside from those, some contractors deal directly with us in response to our advertising campaign with other contractors dealing with us due to requirements from project owners.

In regards to distribution through authorized dealers, we currently distribute our products through 48 dealers especially in Bangkok and northeastern regions. These authorized dealers are responsible for acquiring new potential customers as well as providing installation services. In order to gain more far-reaching distribution channels, we plan to expand our service coverage area to the northern and southern regions to increase in number of authorized dealers.

## **3.7 Industrial Outlook and Competition**

### **3.7.1 Industrial Outlook**

The world economy in year 2010, IMF expected to grow at 4.8% and trend in year 2011 is likely grow at 4.2% which is a bit slowdown from previous year due to recovering of world trade factors and flow of funds of investment. While, the high unemployment rate in many countries such as the U.S. and EU as well as debt crisis in Europe, currency fluctuation risk including cutting the economic stimulating projects by its own government in many countries. These factors will put pressure on the recovery of world economy and also affect to financial market that has more risk of instable conditions. But the strong economic growth in developing countries is a key factor driving to recover. In year 2011, inflation is likely at 3.3% as well as unemployment rate is 8.0 %. Regarding the global financial situation, most central banks of many countries will raise interest rate gradually in order to maintain economic stability and control inflation.

In regarding Thai economy in year 2010, in Q3/2010 GDP grew by 6.7% which was slowdown from Q2/2010 at 9.2% as well as increasing from Q3/2009 that was shrink at -2.8% . However, the Office of the National Economic and Social Development Board (NESDB) expected GDP is likely grow to 7.9 percent in year 2010.

The production of steel and mild steel in year 2010 was around 8,158,980 metric tons (exclude the semi-finished steel, cold rolled steel sheet, coated steel sheet and steel pipe, to avoid repetition), increasing to 17.0% compare with previous

year. Due to domestic demand started recovering in first half year by manufacturing to compensate for the lower stock in previous year, including related industrial expansion especially automotive and electronic industry that both export were high caused continuously expand for steel consumption rate as well as resulting to expansion of manufacturers. Moreover, it is also the result of the base year (year 2009) is low due to the global economic slowdown resulted in the production in base year is low as well. Considering in detail found that flat product increased by 28.93% as well as other coated steel increased to 23.10% , resulting the demand of automotive and electronic continuously increased, while long product also increased to 11.38% as follow table ;

Table 1 : Steel and mild steel production in year 2010 and 2009

Products	Year 2010* (Metric Ton)	Year 2009 (Metric Ton)	Percentage of changing
Semi-Finished Products	4,267,778	3,659,915	16.61
Long Products	4,028,939	3,617,175	11.38
Flat Products	6,892,143	5,345,512	28.93
- Hot-rolled Flat	4,124,459	3,350,547	23.10
- Cold-rolled Flat	1,903,696	1,225,102	55.39
Coated Steel	883,151	769,863	14.72
- Galvanized Sheet	253,575	253,381	0.08
Products	Year 2010* (Metric Ton)	Year 2009 (Metric Ton)	Percentage of changing
- Tin plate	424,107	388,296	9.22
- Tin free	424,107	388,296	9.22
- other coated steel	201,822	128,186	57.44
Pipes & Tubes	N/A	N/A	N/A
Total (1)	8,158,980	6,967,722	17.10

Source : Iron and Steel institute of Thailand

Remark 1 : Excluded the semi-finished steel, cold rolled steel sheet, coated steel sheet and steel pipe, to avoid repetition.

\* The estimate of the Office of Industrial Economics

Coated steel sheet business, with specialized roof and wall solutions for industrial plant establishments, decreased growth performance following the slowdown of manufacturing sector. Current roof and wall cladding market for coated metal sheet products, consists not only of new industrial plant but also existing well established ones in search of substitute and more durable roofing materials for their plant renovation.

### 3.7.2 Competition

#### (1) Indirect Competitors and Substitute products

Roofing and walling material products are capable of meeting variety of require applications. The commonly used roofing and walling materials in Thailand consists of 3 main groups as follow:

(1.1) Asbestos Tiles: This material gains highest popularity for application in residential and industrial plant in Thailand due to its affordable price range between Bt. 130 to Bt. 170 per square meter. Asbestos tiles carry fire-proof, heat – insulating and sound-proof functionality.

(1.2) Concrete Tiles: This material presents elegance along with strength, however, with disadvantages of weight and prices of Bt. 280 to Bt. 350 per square meter compare to Asbestos tiles. Also heavier materials required additional expenses in truss structure to support its heavy weight. They are principally used for residential establishment.

#### (1.3) Coated Steel Sheet divided into 2 categories

(1.3.1) Galvanized Steel Sheet: light weight with approximately 5-year utilization and with the disadvantages of weak rust resistance and less heat proof. Galvanized steel sheet were mostly used in regions outside Bangkok due to its low price, rage under Bt. 100.00 per square meter.

(1.3.2) Roll Forming Metal Sheet: Aluzinc coated roll forming metal sheet, marketed at approximately Bt. 200 to Bt. 300 per square meter depend on metal and coating thickness, offer 4 times utilization longer than galvanized steel sheet.

We believed that in the future, coated steel sheet will take over the market from both Asbestos and Concrete Tiles due to the following factors.

**1. Health Safety:** Roll forming metal sheet has high tendency to supersede asbestos tiles because of the fact of asbestos, used as heat insulator in asbestos tiles, has been medically negative effects to human health, in case studies indicate that damaged asbestos tiles are results in human inhalation exposure that resultantly leads to accumulation and causes lung cancer. Therefore, asbestos tiles are prohibited in developed countries such as the U.S. and Australia. Additionally, ISO 14000 certificated industrial plans are required to discontinue the asbestos tiles for plant environmental safety. Due to these factors, utilized asbestos tiles amount industrial plant has tendency towards decline, especially in export food processing facilities.

**2. Compatibility and Long-term Worthiness:** Roll form metal sheet's durability, lengthy anti-leakage, high resistively to erosion effects and rust resistance features make it ideally compatible with application for industrial plant or resident buildings. Most industrial plants are willing to burden higher roofing expenses in exchange for necessary protective

features e.g. anti-leakage to re-assure that their finished goods are safe from potential leakage damages. Additionally, roll forming metal sheet is designed for convenience, fast and cost saving installation and allows variety of customized bending requirement, added elegance to the building. Its maximum to 30 years warranty provides assurance of long-term worthiness

**3. Cost and Installation Competitiveness:** Despite higher prices per square meter in comparison to asbestos tiles, roll forming metal sheet possess lighter weight, requires less truss to support the material and less expenses in connection with overall building structure.

## (2) Direct Competitors

Currently, the competition in roll forming metal sheet industry is more severe. The fierce competition is generally centered on prices, product quality and design including after-sales service. Players in roll forming metal sheet industry consist variably of both distributor and distributor/manufacturer. Distributors can enter into business fray easily but has a disadvantage in price competition, as well as lack of expertise on both pre and after sales services, which become their main encumbrances in the competitiveness. For distributor/manufacturer, there are 3 major players in Thailand with hold 52% of the total market share; they are BlueScope Lysaght (Thailand) Company Limited, which is as associated company of BlueScope Steel (Thailand) Company Limited, Siam Steel Service Center Public Company Limited and Bangkok Steel Industry Public Company Limited. Besides these three players, they are small and medium scale manufacturers.

Competitive edges in roll forming metal sheet industry are composed of raw material, quality, installation service performance, pricing capability, roll forming in response to customer requirements, working capital liquidity and after-sales service. Large-scale manufacturers have advantages over product diversification and stronger financial fundamentals, which enable them to support large-scale installations. Large-scale manufacturers therefore aim at large-scale projects as their targeted customers. Medium-scale manufacturers including Steel Intertech have the market share of 18%; aim at medium to small-scale projects especially industrial plants as targeted customers. Small-scale manufacturers held 30% market share, are unfavorable positioned due to less working capital, less product diversification, cost of goods sold and less capability to handle large-scale project. The company is one of the medium scale distributors/manufacturers, but better equipped than the other counterparts in the following factors:

- (1) 16-year of experience, sharpen the business expertise, extensive customer base and constant growth performance. There are more than 800 industrial customers under the company customer base.
- (2) Our internally developed “ROLLFORM” patented brand name encourages stronger awareness and realization among customers of our brand identity, product quality and service.
- (3) We are one whose qualified manufacturers that have been granted to print “Steel Supplied by BlueScope Steel” emblem on our products from our business alliance – BlueScope Steel (Thailand) Company Limited, who is Thailand’s major manufacturer of Aluzinc-coated roll forming metal sheet products. BlueScope Steel is our entire raw materials supplier, which is well recognized in the world industry for its world class standards. Purchased our products with the said emblem printing, is entitled to receive a product warranty certificate directly from BlueScope Steel.

- (4) We focus on meeting customers' need and increase their choices through product innovation in order to diversify existing product ranges. To preserve our emerging business opportunity, we offer fast service coupled with production flexibility in responding to customers demanded timeline.
- (5) Our well selected 30 authorized dealers provide extensive market penetration and product presence, especially in those small-scale in remote areas. We are currently expanding our distribution networks to provide coverage in Northern and Southern regions.

Despite the intensity of competition in roll forming metal sheet industry was high together with there are many players, however, considering the 32% annual growth rate in the number of newly approved industrial plants, coupled with potential requirement for more durable roofing material amount those existing industrial plant, we are convinced that roll forming metal sheet industry has a bright outlook in the future. Furthermore, we believe that, with our competitive edges, will drive further sales growth.

### 3.8 Product Provision

#### 3.8.1 Raw Material Procurement

Raw materials required for roll forming metal sheet manufacturing is Aluzinc-coated cold-rolled steel with and without clean COLORBOND. All of which are wholly procured from BlueScope Steel (Thailand) Company Limited ("BlueScope Steel"). BlueScope Steel is a major manufacturer of Aluzinc-coated cold-rolled steel with and without clean COLORBOND used as raw materials for roll forming metal sheet. BlueScope Steel carved market share in 2010 at approximately 70% and supplied raw materials to about 40 domestic roll forming metal sheet manufacturers.

BlueScope Steel is a subsidiary of BlueScope Steel Limited in Australia and New Zealand. It is the largest manufacturer of steel and metal sheets for construction, automotive, packing industries. It's most popular product and best performer is Aluzinc-coated steel. BlueScope Steel Limited has manufacturing base in Australia, Southeast Asia, Central and Northern Asia, Oceania and the U.S. BlueScope Steel Limited is currently a public listed company on Australian Stock Exchange. (Source: [www.bluescopesteel.com](http://www.bluescopesteel.com))

Manufacturing and distribution in Asia-Pacific region of BlueScope Steel Limited is under supervision of Asian Building and Manufacturing markets Section, which clearly separates between Aluzinc-coated steel and roll forming metal sheet business lines. For example, Thailand is one of BlueScope Steel Limited's manufacturing based in Asia-Pacific region. BlueScope Steel Limited managed to enter into joint venture agreement with Loxley Public Company Limited at 75% and 25% investment ratio respectively to establish BlueScope Lysaght Company Limited ("BlueScope Lysaght") in 1998 for manufacturing and distribution of Roll former through import of coated steel. Afterwards, BlueScope Steel (Thailand) Company Limited was established in 1995 for purpose of manufacturing and distribution of Aluzinc-coated steel with and without clean COLORBOND – a major material used for roll forming metal sheet manufacturing. BlueScope Lysaght then started to procure all of its raw materials from BlueScope Steel; the two companies have become associated ever since, with

shareholders and directors in common. However, BlueScope Steel has policy to make business transaction with BlueScope Lysaght as Arm's Length Basis in response to its mother company's policy to make a clear division for each business line.

BlueScope Steel ranks its customers based on order volume and frequency to determine selling prices and credit facility granted on case by case basis. We are one of the selected BlueScope Steel's top ten red customers due to our strengths as follow: 1) monthly order exceed 300 tons (average order of the last 3- month); 2) clean payment record; 3) order raw material solely from BlueScope Steel , earning the privilege in price and credit term. Payment by local currency (baht) reduced the risk in exchange rate fluctuation.

### **Raw material price trends**

In 2010, the consumption of steel and mild steel in Thailand was 14,210,985 metric tons approximately, increasing to 44.33% comparing to the same period of previous year caused by the base year low (due to the beginning of year 2009 to Q3/2009 the manufacturers still had their stock that made to reduce order, resulting to reduce production down as well. Therefore, when comparing the steel consumption rate between year 2010 and 2009, indicated that the volume add up. In regard steel consumption, both were flat products and long products increasing to 64.74% and 10.87%.

The overview of steel situation in 2010, comparing to the same period of previous year found that the production increased of 17.10%. Domestic demand increased of 44.33%. In regarding, the total value and volume of import also increased 60.32% and 52.29% respectively, caused by increasing of pickled and oiled hot-rolled sheet up to 136.45%, following was hot-dip galvanized steel also increased to 117.29 % and chromium coated steel increased to 104.28%. Due to China is exporting steel, which is cheaper than steel produced in Thailand. A resulting to entrepreneurs in related industries e.g. canned food industry which required more raw materials from China. Moreover, Thai baht currency was also stronger than U.S currency this resulting to related industry entrepreneurs required more steels from oversea. Regarding, the total value and volume of export up to 21.52% and 16.10% respectively caused by increasing of other semi-finished products at 203.32% , seamless steel up to 118.11% as well as cold-rolled flat up to 99.17%.

The steel industry trend in year 2011, is likely growth continuously due to both the construction and manufacturing sectors expected to grow. Despite a global economic outlook remains subject to fluctuations and currency problems. The construction sector still has new opportunities from private investment, especially investment in infrastructure in year 2010 which already bid and prepared construction projects. While the automotive industry is likely grow in high rate due to eco-car production. The electronic and canned food industry is expected to be in shape at the other because of the limitation of production base in year 2010.

Despite all major steel prices in the world market adjusted up to raw material price. To preserve our market share according to company policy, therefore its sales was remain in pricing, which made gross margin decreased. In order to make customer confidence in services which is under company's aspiration as "Solution Provider" in long term. Besides this, the other complimentary e.g. insulation, screw are generally available products, flexible providing and able to purchase from several suppliers in country by selecting of product quality.

### 3.8.2 Manufacturing and Installation

Our head office and manufacturing facilities are located on 1.18 acre plot of land, at No. 8 Moo 15, Soi Kingkaew 11, Bangplee-yai, Bangplee, Samutprakarn 10540. The production capacity of metal sheet is more than 13,400 tons per year or approximately 3,000,000 sq. m. per years, the production capacity of C & Z Purlins total 2,000 tons per year or approximately 500,000 meters per year.

Roll Form	Production Capacity (sq.m./year)	Production output 2008		Production output 2009		Production output 2010	
		Sq.m.	%	sq.m.	%	sq.m.	%
Metal sheet	3,012,000	900,157	29.89	727,289	24.15	821,884	27.28

Purlins	Production Capacity (m./year)	Production output 2008		Production output 2009		Production output 2010	
		m.	%	m.	%	m.	%
CEE-ZED PURLIN	500,000	68,773	13.75	60,913	12.18	60,247	12.05

#### Production Process

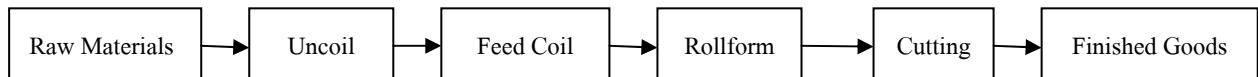

Production process starts with uncoiling of raw materials (coiled metal sheet) with or without clean COLORBOND as per customers' requirement. Then the uncoiled metal sheet is fed to the roll forming machine to produce required model, length, and quantity. Each sheet will be cut to length and be individually inspected on its width and length to meet customers' requirement. The production process takes one day to complete, each single step from the raw material to the final product will be inspected to meet the standard of ISO 9001:2008.

Most of the products are made to order, there is no limitation in length, as our plant can accommodated large transport truck to pick up the products. We also offer the on-site production, in the event of the length is longer than the truck loading capacity. With more than 10 year experience, we are well equipped with experience personal. The products also carry 5 to 30 years warranty on color quality and rust resistance, depended on the coating layer. Warranty certificate, was issued by BlueScope Steel (Thailand) Company Limited, who is the raw materials supplier with Australian 1397-2001 International Standard.

### **Installation management**

Aside from production, installation service plays an important role in our integrated service provider. Therefore, installation management is critical for our business operations because it contributes directly to the effectiveness of budget administration for any given project. We plan to boost our sales for integrated product and installation package in the future. As we are well aware of the importance of installation service, we set out the following installation management systems as follow:

1. Selecting of Subcontractor: We do not hire installation personnel of our own. Instead, we hire qualified subcontractors to carry out installation service to customers as generally practice by other counterparts in the same industry, such as BlueScope Lysaght Co., Ltd. This approach enables us to be more cost efficient than hiring full-time personnel. Selection criteria for qualified subcontractors are composed of previous accomplishment records, financial position, available workforce and output quality and operation potentials. As of December 31, 2010, we maintained 28 qualified subcontractors; most of them have been in business more than 5 years. We devise a policy to continuously selected qualified subcontractors to handle large project in order to boost up company's sales for integrated product and installation package.

2. Work Allocation to Subcontractor: We match project received with the most suitable subcontractor based on resources and potential of each subcontractors without relying on a single subcontractor. All of our subcontractors, 12 of them are capable of handling large scale project with the roofing area more than 5,000 sq. m., 16 of them are capable of handling medium scale project with the area between 1,500 to 5,000 sq. m. The medium scale project is the large part of our total projects, which allow us to find the suitable matched. In case, there are multiple large-scale projects due at the same time, we will allocate a few medium-scale subcontractors to perform a joint operation. With this flexible approach, we have never been faced with shortage in installation subcontractors.

3. Installation Quality Control: Every projects have been controlled by our engineering personnel (site supervisor), on the installation quality, as well as evaluated after the completion to assure the project owner of the installation quality. Subcontractor provides 1 year warranty after work delivered.

4. Punctual Delivery: Our subcontractors are required to report the installation progress of 15 days periodically, which allows the company to take immediate action if the installation is behind schedule. However, subcontractors are subject to total indemnification for any delay caused by their own action.

### **3.8.3 Environmental Impact**

- None -

## 4. Risk Factors

### 1. Business Risks

#### 1.1 Entire Dependency on Major Raw Material Supplier

We purchase main materials - Aluzinc-coated cold-rolled steel with and without clean COLORBOND, solely from BlueScope Steel (Thailand) Company Limited (“BlueScope Steel”), which is 89.27 of total raw materials. Therefore, discontinuance of BlueScope Steel will have significant impact on our operation.

However, BlueScope Steel is a major manufacturer of cold-roll Aluzinc coated metal sheets and is one of the two suppliers in COLORBOND metal sheet in Thailand. It is also a subsidiary of BlueScope Steel Limited in Australia. Currently, BlueScope Steel’s production capacity is approximately 380,000 tons per annum which, more than previous year around 100,000.00 tons. The quantity considered well beyond our annual requirements. In addition, BlueScope Steel ranks its customers based on order volume and frequency to determine selling prices and credit facility grant on a case-by-case basis. We have forged business relationship with BlueScope Steel for several years since 1997, through regular raw material orders which clean records of defaults. Because of strong business ties and trust, we ranged in first rate customer (Red Customer). We contribute 4% to BlueScope Steel’s total sales. In addition, we managed to enter into agreements for more favorable terms and conditions related to raw material procurement. Among the agreement, we are granted to use its emblem “Steel Supplied by BlueScope Steel” long with our own ROLLFORM ® brand name on our products. Due to the afore mentioned reasons, we are convinced that BlueScope Steel will continue delivering their products to the industry with ongoing customers’ acceptance, and remain being our major raw material supplier. However, we are alternatively able to import the same type of raw materials from manufacturers in Korea and Japan.

#### 1.2 Having Associated Company of BlueScope Steel as Competitor

A sole supplier on company raw material, BlueScope Steel, has BlueScope Lysaght (Thailand) Co., Ltd., as shareholder and committee. BlueScope Lysaght (Thailand) Co., Ltd. was established in 1988, performing the business of manufacture and distribute of coated metal sheet roll form, same as ours, with the same raw materials from BlueScope Steel. Therefore, BlueScope Lysaght (Thailand) Co., Ltd. has the advantage on the condition and price, which will not allow us to compete in the same market. This will affect the company operation in the future.

The major shareholder of both companies, which is BlueScope Limited Australia, has the clear cut policy to separate two businesses, the manufacture of steel coated metal sheet and roll forming metal sheet therefore BlueScope Steel has treated BlueScope Lysaght (Thailand) Co., Ltd., in the same manner as other roll former. BlueScope Lysaght (Thailand) Co., Ltd., is also rated as a outstanding customer (Red customer) as same as Steel Intertech (Thailand) Co., Ltd., which assured us that both conditions and prices received is in the competitive level. However, BlueScope Lysaght (Thailand) Co., Ltd., has the market share of 29%, which the company has the 5%. BlueScope Lysaght (Thailand) Co., Ltd would get a lower price from the high volume order. To be competitive in the market, the company focuses on the speedy services in meet customers’ time line and brand building “ROLLFORM” to develop company’s own market. The number of customers, who

realize the quality and the services under the mentioned brand, has been continuously growing, enable direct sales to the project owner, which are large-scale project, therefore decrease in sales to small-scale project.

### **1.3 Raw Material Price Volatility**

In general business operation, reserved raw material is required to meet customers' demand. The major raw material of the company is cold-roll metal sheet, which is 79.52% of the total raw materials. The price of the coated metal sheet is tied to the price of the cold-roll steel sheet, if the market price is lower than the stocked raw material, the company will not be competitive in the market, likewise, if the market price is increased and the company doesn't have enough stock.

However, the company has been followed the raw material price trend, and adjust the ratio of reserved raw material. The company has price strategy to go along with the cost of material, which reduces the effect of Raw Material price Volatility.

### **1.4 Installation Service by Subcontractor**

The company does not have its own installation team; it hires a subcontractor with the ratio of revenue to sales and installation in fiscal year 2008, 2009 and 2010 to be 37.69%, 48.96% and 52.59 respectively. As the ration of sales and installation has been continuously increased, the company risks losing installation control. If the company cannot hire the subcontractor or cannot control the installation quality, these may cause installation delay, which will effect cost of project and affect the company's operation expenses.

However, the company was decreasing in sales and installation, the company still managed the installation which can be controlled payment and also remain the high quality by the significant method follow:

**(1) Selection of Subcontractors:** We do not hire installation personnel of our own. Instead, we hire qualified subcontractors to carry out installation service to customers, which enables us to be more cost efficient that hiring full-time personnel. Selection criteria for qualified subcontractors are composed of previous accomplishment records, financial position, available workforce, output quality and operation potentials. As of December 31, 2010, we maintained 28 qualified subcontractors; most of them have been in business more than 5 years. We do not rely on only a few subcontractors and never have problem of lacking workforce or unfinished project.

**(2) Installation quality control:** Every projects have been controlled by our engineering personnel (site supervisor), on the installation quality, as well as evaluated after the completion to assure the project owner of the installation quality. Subcontractor provides 1 year warranty after word delivered.

**(3) Punctual Delivery:** Our subcontractors are required to report the installation progress of 15 days periodically, which allows the company to take immediate action if the installation if behind schedule. However, subcontractors are subject to total indemnification for any delay caused by their own action.

### **1.5 Competitive Pressure from substitute Products**

The major product that the company manufactures and distributes is Aluzinc coated roll forming metal sheet for wall and roof, which can be substituted by other products, e.g. asbestos, zinc coated steel sheet, which offers customer

choices. Not only the metal sheet price is higher in comparison to concrete tiles or zinc coated steel sheet. If customers chose other substituted products, this will affect the company's future revenue significantly.

However, each product has its own strength and weakness. The qualification of the company's products is high resistance in erosion and anti-leakage, with the maximum usage of 30 years, no environmental effect, easy and fast installation, which are necessary qualifications needed by industrial plants, who are the targeted customers. These qualifications cannot be replaced by other products. Risk from substituted products is low, considering the continuously increasing in sales.

## 5. Shareholding Structure and Management

### 5.1 Top Ten Major Shareholder

Our registered capital values Bt. 500 million, consisting totally of 500 million common shares at Bt. 1 par value. All the common shares are issued and paid up with total value of Bt. 50 million.

List of Major Shareholders as Appeared in Registration Book as of September 1, 2010 as following;

Name	Share Volume Owned	%
1. Ounvorawong Family*	23,526,900	47.05
2. Mrs.Kasemsri Wannarote	4,241,700	8.48
3. Mr.Nat Whangmahaporn	3,000,000	6.00
4. Mr.Supote Wannarote	1,086,000	2.17
5. Mr. Wichien Chiekcherm	1,074,200	2.15
6. Mr.Piyapassorn Dornchandaeng	1,000,000	2.00
7. Mrs. Wiroonsri Taifayongwichit	894,000	1.79
8. Mr.Taweepan Chantarapan	786,400	1.57
9. Mr.Siriwat Taifayongwichit	745,600	1.49
10. Other Shareholders	13,645,200	27.30
<b>Total</b>	<b>50,000,000</b>	<b>100.00</b>

**Remarks:** \* Ounvorawong Family is composed of Mr. Prasit Ounvorawong (13,150,000shares), Mrs. Rossukon Ounvorawong (10,076,900 shares), Mr. Nontakorn Ounvorawong (100,000 shares), Mr. Nuttakorn Ounvorawong (100,000 shares) and Miss Panchanit Ounvorawong (100,000 shares)

### 5.2 Dividend Policy

We devise dividend policy to maintain a minimum of 40% pay-out ratio, out of the net profit achieved in each fiscal year after corporate income tax and legal reserve. Nevertheless, we may occasionally consider determining lower pay-out ration for any fiscal year should there be additional financial requirements for further business investment.

5.3 Management

Organization Chart (As of December 31, 2010)

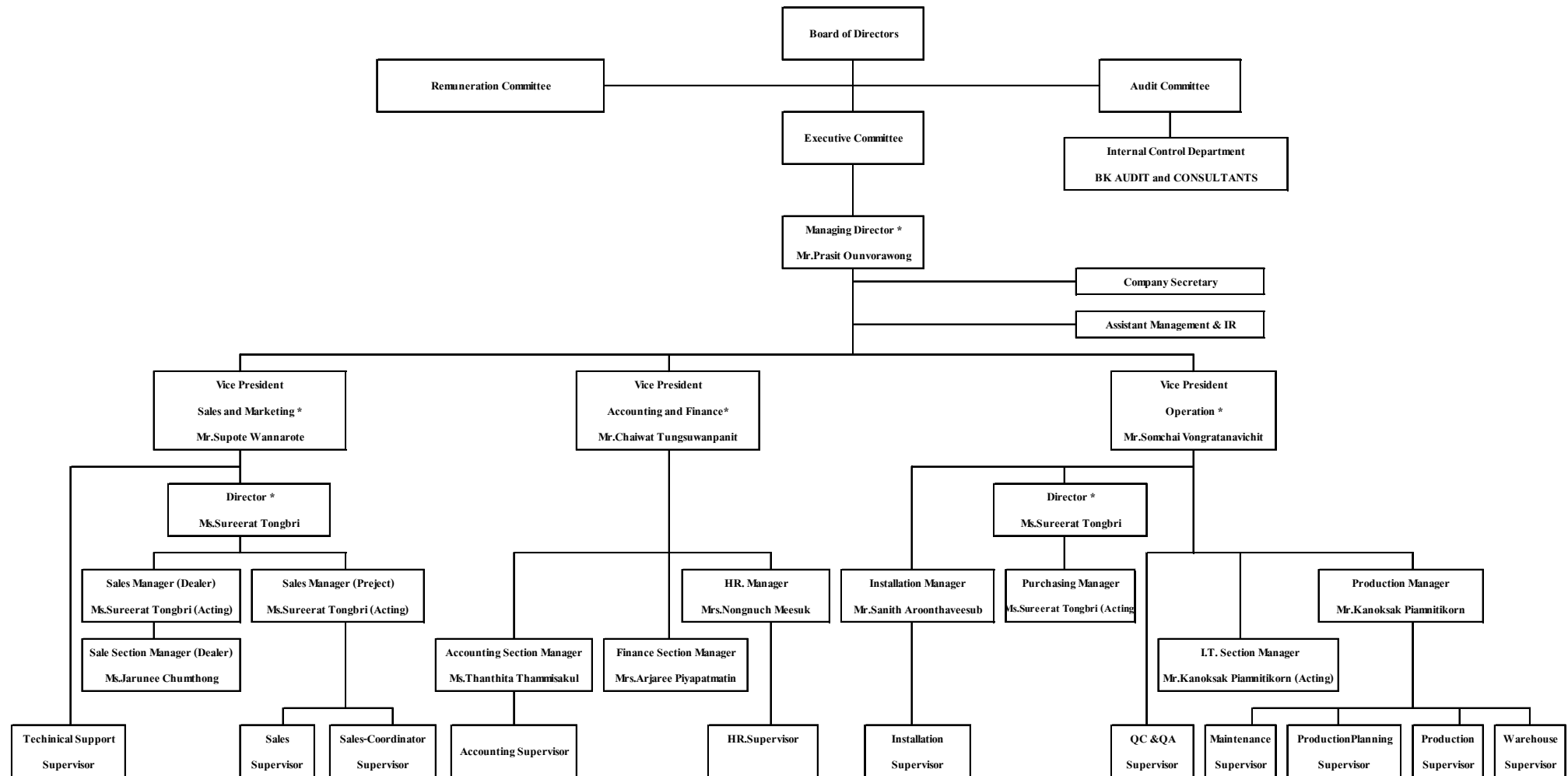

Remark : \* Management as per Securities and Exchange Commission, Thailand's definition

<b>Board of Directors and Executives</b>
--

There are 4 groups of committee, which are Board of Directors, Board of Executive Directors, Audit Committee, and Board of Remuneration Designated, with details as follow:

**Board of Directors**

As of December 31, 2010, the Board of Director is composed of 7 members.

No.	Name	Position
1.	Dr.Suradej Chuntranuluck	Independent Director/ Chairman/Chairman of Audit Committee
2.	Mr. Prasit Ounvorawong	Director
3.	Mr.Supote Wannarote	Director
4.	Ms.Sureerat Thongbri	Director
5.	Mr.Somchai Vongratanavichit	Director
6.	Mr.Lertchai Wongchaiyasit	Independent Director/ Audit Committee
7.	Mr.Numpon Ngunnumchoke	Independent Director/ Audit Committee

**Authorized Director for Legal Binding**

Mr. Prasit Ounvorawong signs in conjunction with Mr. Supote Wannarote or Ms. Sureerat Thongbri

**Authority of Board of Directors**

Board of Directors is authorized to manage the company in conformity with laws, objectives, company regulations and legal shareholder resolutions with honesty, in good faith, and for the best interests of the company. Major authority and responsibilities of Board of Directors are summarized below:

1. Hold Annual Ordinary General Meeting of Shareholders within 4 months following and end of the company's fiscal year.
2. Hold Board of Directors' Meeting on a quarterly basis in minimum
3. Oversee preparation of balance sheet and profit & loss statements at the end of the company's fiscal year and propose the audited sheet and statements in Shareholders' meeting for consideration and approval.
4. Authorized one or more directors or other person deemed appropriate to implement any given task on behalf of and under supervision of the Board of Directors Alternatively, the Board of Director may consider giving such person an authority deemed appropriate and within agreed course of time. Such

authorization or authorized person may be subject to alterations as deemed appropriated. Board of Directors may also consider giving authority to Board of Executive Directors to carry out any given tasks in accordance with the authority and responsibilities of Board of Executive Directors, provided that such authorization does not cause conflict of interests between Executive Directors/other persons with the company and subsidiary.

5. Set business goals, guidelines, policy, business plan and corporate budget, as well as oversee management and policy implementation by Board of Executive Directors in line with devised policy. The following issues require prior shareholder approval: any action that, by law, requires shareholder resolution, such as altering the company's par value or registered capital, debenture issuance, sale or transfer of significant business in part or in whole to other persons, acquisition of other business, amendment to the company's Memorandum of Association and Articles of Association, etc. In addition, Board of Directors has authority and responsibilities to ensure corporate compliance with relevant stock exchange legislation, rules and regulations set by the Stock Exchange of Thailand, such as inter transaction, acquisition or disposal of significant assets pursuant to the SET regulations and laws related to the company's business.
6. Review management structure and consider appointment of Board of Executive Directors, President and other committee as deemed appropriate.
7. Ensure implementation of business plan and budgeted expenditure on a continual basis.
8. Not being engaged in operations of any enterprise of similar business nature or in competition with the company's business; and not enter into partnership agreement of any kind or directorship with any privately owned business or enterprise of similar business nature or in competition with the company's business for the sake of either personal interests or interests of other persons, except for prior notification to Shareholders' Meeting before being appointed as director.
9. Disclose the company without delay any matter interests, whether direct or indirect, in the company's transactions or increase/decrease in securities ownership in the company or subsidiary.

#### **Board of Executive Directors**

There are totally five Executive Directors as follow;

<b>No.</b>	<b>Name</b>	<b>Position</b>
1.	Mr. Prasit Ounvorawong	Managing Director
2.	Mr. Supote Wannarote	Executive Director
3.	Mr. Somchai Vongratanavichit	Executive Director
4.	Ms. Sureerat Thongbri	Executive Director
5.	Mr. Chaiwat Tungsuwanpanit	Executive Director

### Authority and Responsibilities of Board of Executive Directors

Board of Executive Directors has authority and responsibilities to manage the company's operations in normal course of business as well as to set policy, business plan, budget requirements, management structure and authority and set business criteria in accordance with economic environment. All the afore-mentioned authority and responsibilities are subject to further consideration for approval by Board of Directors. Board of Executive Directors is also responsible of the Board of Executive Directors.

1. Plan and devise business policy, direction, strategy, plan and main organizational and management structure in accordance with economic and market environment and submit to Board of Directors for approval.
2. Plan and set business plan, annual budget and management authority in different operation lines and submit to Board of Directors for approval.
3. Follow up and ensure that corporate policy and management guidelines are implementing in efficient manner and in response to industry environment.
4. Consider approval and bidding for assignment implementation with state agency or persons with maximum value of not over 25 million baht.
5. Make decision to employ or terminate management level personnel, except for Managing Director or management personnel who hold director position.
6. Oversee and ensure day-to-day implementation of Board approval business plan.
7. Sign accounting papers for withdrawal of commercial bank deposit in accordance with conditions and granted facility as occasionally permitted by Board of Directors.
8. Be authorized to approve payment as determined in Board-approved annual budget, which allows Board of Executive Directors to approve payment for expenses at unlimited ceiling.
9. Enter into agreement that gives rise to binding effects to the company for between one to three years with maximum value not over 25 million baht.
10. Invest in capital expenditure with maximum value of not over 25 million baht or as determined in Board approved annual budget.
11. Provide funds for financing Board approved investment or investment in capital expenditure or provide funds for refinancing existing debts under more favorable terms and conditions.
12. Consider approval for yearly bonus payment to employee in accordance with Board approved budget.
13. Consider approval for remuneration increment for employee in accordance with Board approved budget.
14. Perform other duties as occasionally assigned by Board of Directors.

Board of Executive Directors may consider assigning its financial approval authority to certain management level staff in order to implement on or more tasks under certain scope of authority, which Board of Executive Director deems appropriate.

In addition, the above-mentioned assignment of authority to Board of Executive Directors must be in compliance with Articles of Association. In the event of any task implementation that involves or may involve the vested interests or conflict of interests of any Executive Director or other persons (pursuant to notification of the Securities and Exchange Commission), Board of Executive Directors is required to submit the said issue to Board of Directors for further consideration. In such Board of Directors' Meeting to consider the said issue, the Executive Directors or person of vested interests or conflict of interests has no right to vote on the issue.

In addition, any task related to inter transaction or acquisition or disposal of significant assets of the company or subsidiary as the case may be pursuant to the notification of the Stock Exchange of Thailand shall require prior to shareholder approval and/or any other compliance with criteria and procedures as stipulated in the said notification in order to be in conformity with the Stock Exchange of Thailand's requirements governing the said issue.

#### **Authority and Responsibilities of Managing Director**

1. Manage the company's operations in normal course of business as well as manage general day-to-day business operations in accordance with Board approved business policy, plan and strategy.
2. Be authorized to any transaction in normal course of business, including preparing proposal, entering into agreement, purchasing and employment with maximum value of not over 10 million baht per item or in accordance with authorization regulation as occasionally determined by Board of Director.
3. Assign management authority and responsibilities to the company's management of employee according to Board approved organization chart and in compliance with relevant legislation and articles of Association.
4. Be authorized to assign authority and/or assign one or more tasks to other persons for implementation on behalf of Managing Director within the scope of Managing Director's authority as determined herein or in compliance with legislation. The said assignment of authority must be conducted in compliance with legislation, Articles of Association, order or resolution of Board of Directors and/or the company.
5. Be authorized to make decision with regards to employment, appointment, relocation, dismissal, termination of employment, remuneration determination for employee of lower than management level, as well as appointment of employer representative attached to the company's Providence Fund Committee.
6. Be authorized to issue order, regulation, announcement and memorandum in connection with employee work execution in order to fulfill company policy and for the best interests of the company and organizational discipline.
7. Perform other duties as occasionally assigned by Board of Directors.

The work executive of Managing Director is under supervision of Board of Directors in order to ensure conformity with Board approved business policy and compliance with legislation, regulation and Articles of Association. Managing Director is required to turn Board approved business policy into practice along with periodic report of implementation progress directly to Board of Directors.

In order to execute the above mentioned work, Managing Director is required to comply with relevant legislation and Articles of Association such specific legislation, regulation, or Articles of Association exist, In the event of any work execution related to or may be related to vested interests or conflict of interest of Managing Director, or any work execution related to person with conflict of interests, as determined in the notification of the Stock Exchange of Thailand, Managing Director shall have no authority to approve such issue. Managing Director is required to submit such issue to Board of Directors for further consideration.

In addition, issue of inter transaction or acquisition or disposal of assets of the company or subsidiary as the case may be, as determined in the notification o the Stock Exchange of Thailand, requires prior approval from Board of Directors' or Shareholders' Meeting and/or any compliance with criteria and procedure determined in the said notification. This is aimed to preserve business transparency and to promote the best interests of shareholders.

### **Audit Committee**

The audit committee of company consists of 3 members as follow;

<b>No.</b>	<b>Name</b>	<b>Position</b>
1.	Dr. Suradej Chuntranuluck	Chairman of Audit Committee
2.	Mr. Lertchai Wongchaiyasit	Audit Committee
3.	Mr. Numpon Ngunnumchoke	Audit Committee

All three members of Audit committee possess independence in their work execution in accordance with the definition of independent director as follow:

1. Director who owns not over 5% of the total shares eligible for voting of the company, parent company, subsidiary, associated company or person with probable conflict of interests.
2. Director who is not an employee, staff, advisor or authorized decision maker of the company, parent company, subsidiary, associated company or person with probable conflict of interests.
3. Director who has no family relationship or legitimate relationship with person with probable conflict of interests.
4. Director who has no business relationship with the company, parent company, subsidiary, associated company or person with probable conflict of interests in the manner that may jeopardize independent judgment.
5. Director who possesses no other quality that may jeopardizes expression of independent opinions about the company business operation.

### Authority and Responsibilities of Audit Committee

Audit Committee has authority and responsibilities as follow:

1. Review financial statements to ensure fair and complete presentation and adequate disclosure.
2. Review the company's administration of internal controlling system and internal audit as appropriate and adequate. Consider the independence of internal audit department as well as approval in appointment, relocation, dismissal of the head of internal audit department or other department that responsible regard to internal audit.
3. Review the company's compliance with legislation of the Stock Exchange of Thailand, regulation and Articles of Association of Stock, related its business law.
4. Consider, select and appoint the company's independent auditor and remuneration based on performance reliability, including attends the meeting with the auditor at least once a year without management team.
5. Consider disclosing the company's information with regards to inter transaction or conflict of interest in accordance to regulation of the Securities and Exchange to ensure that most reasonable to the company.
6. Prepare task implementation report of Audit Committee and disclose in the company's Annual Report. This said task implementation report, signed by Chairman of Audit Committee, must contain of the following information ;
  - 6.1 Opinions about fairness, completion and reliability of preparation and disclose of the company's financial information.
  - 6.2 Opinions about adequacy of the company's administration of internal controls.
  - 6.3 Opinions about compliance with legislation and requirements of the Stock Exchange of Thailand or with business related legislation.
  - 6.4 Opinions about the appropriateness of the independent auditor.
  - 6.5 Opinions about any items that may have a conflict of interest.
  - 6.6 The number of meetings of the audit committee and attendance of each member of the audit committee.
  - 6.7 Comments or observations by including the Audit Committee received from its duties under the Charter
  - 6.8 Any other reports deemed necessary from disclosure to investors and the public under the scope of authority and responsibilities assigned by the Board of Directors.
7. Perform other duties as assigned by Board of Directors of the company with the approval of the Audit Committee.

### Remuneration Designated Committees

The company has 3 remuneration committees as follow:

No.	Name	Position
1.	Mr. Lertchai Wongchaiyasit	Chairman of Remuneration Committee
2.	Mr. Numpon Ngunnumchoke	Remuneration Committee
3.	Mr. Prasit Ounvorawong	Remuneration Committee

### Scope of responsibility of the Remuneration Designated Committees

Remuneration Designated Committees have the following duties:

1. Evaluate the performance of the committees, sub-committees and the Managing Director every year.
2. Consider the remuneration to the committees, sub-committees, including the monthly remuneration, meeting expenses, yearly bonus and other benefits, both in form of monetary and non-monetary, by using the fair and reasonable criteria or methods and structure, to propose to the shareholders to approve.
3. Consider the remuneration to the Managing Director, including the monthly remuneration, meeting expenses, yearly bonus and other benefits, both in form of monetary and non-monetary, by using the fair and reasonable criteria or methods and structure, to propose to the shareholders to approve.
4. Consider the remuneration to the committees, sub-committees, Managing Director, according to the performance result, company operating result, industrial procedures and leading registered company in the Stock Exchange Market of Thailand and the scope of responsibility
5. Perform other duties as assigned by the Committees.

### Company Secretary

In compliance with new legislation and requirements of the Stock Exchange of Thailand, the meeting of committees was held as 2/2008 on May 14, 2008, passed as resolution to appoint Ms.Ratima Ngamsa-nga as a company secretary. This would be effective on September 1, 2008 onwards, with responsibilities as follow;

1. Create, maintain and keep a central filing systems for followed documents;
  - A. Registration of committee
  - B. Appointment letter for committee meeting, minute of meetings and annual report.
  - C. Shareholder appointment letter and annual general meeting report
2. Keeping the interest report that reported by committees or company executives.
3. Perform other duties pursuant to the notification of Capital Markets Board of Committee.

### Selection of Director and Executive Committee

The company had no nominating Director and Executives Committee, in particular the selection of persons who will be appointed as a director, determined by qualification, knowledge, experience and able to attend the Board meeting consistently. The director will be appointed by the Board majority basis and the following method;

1. Shareholders have one vote per share equal to one on one sound according to they hold.
2. In the election of directors, how ballot are cast of voting shareholders may use its right to vote for anyone eligible to be director individually or several people at once upon the shareholder's meeting deemed appropriate. The votes or resolution of any individual shareholder to exercise the votes are all in accordance with Article 1. Nevertheless, they have not been prohibited to splits how many votes to any other candidates.
3. In regards voting for selection of director, resolution is passed with a majority vote. In case of equal vote, chairman of the meeting will vote and give the binding result.

### Company Executives

As December 31, 2010, the company has 8 executives as follow;

ลำดับ	รายชื่อ	ตำแหน่ง
1.	Mr. Prasit Ounvorawong	Managing Director
2.	Mr. Supote Wannarote	Vice President, Sales and Marketing
3.	Mr. Chaiwat Tungsuwanpanit	Vice President, Accounting and Finance
4.	Mr. Somchai Vongratanavichit	Vice President, Operation
5.	Ms. Sureerat Tongbri	Director
6.	Mr. Kanoksak Piamnitikorn	Production Manager
7.	Mr. Sanith Aroonthaveesub	Installation Manager
8.	Mrs. Nongnuch Meesuk	Human Resources Manager

### 5.4 Remuneration to Executives

#### (1) Financial Remuneration

#### Total Remuneration Paid to Directors.

	2008	2009	2010
Total Remuneration Paid to All Directors in Capacity as Company's Director	541,016	1,161,971	436,930
Number of Directors (Person)	8	7	7

Remarks: Shareholders' Meeting 2010, held on April 27, 2010, passed the resolution to remunerate company's direction set forth below:

Board Meeting Allowance: Chairman of the Board is remunerated at 6,000 baht / session.

Director is remunerated at 4,000 baht/session.

Audit Committee Meeting Allowance: Chairman of Audit Committee is remunerated at 5,000 baht / session.

Audit Committee Member is remunerated at 3,000 baht/session.

Remuneration Committee Meeting Allowance: Chairman of Remuneration Committee is remunerated at 3,000 baht / session.

Remuneration Committee Member is remunerated at 2,000 baht/session.

## **(2) Other Forms of Remuneration**

Board of Directors' Meeting 1/2005, held on March 25, 2005 and passed the resolution raise Providence Fund on behalf of the company and for company's employees. American International Assurance Company Limited is appointed as fund manager. The providence fund, effective on May 26, 2005, is composed of premiums paid by each employee at 3% of his/her monthly salary and another 3% by the company.

## **5.5 Corporate Governance**

The Board of Directors devises own policy of best practices for company's directors, which is consistent with the Code of Best Practices for Directors of Listed Company according to the guidelines of the Stock Exchange of Thailand year 2006. Determinations of such provisions are based on practicality. In addition, we introduce and adhere to the 5 items of Good Corporate Governance as a guideline for our business policy development. This is aimed to ensure efficiency and transparency of our management and business operations, which in turn protect and enhance confidence amount shareholders, investors, employees and all concerned parties, resulting in the following guidelines:

### **Item 1 : Rights of Shareholders**

Recognizing the rights for all shareholders, the company ensures that the shareholders are entitled to all right basis at acceptable and trusted standards, namely the rights to buy new shares, sell, transfer shares, the rights to receive the dividends from the company, to obtain adequate information, the rights to attend the shareholder's meeting, the rights to express opinions freely, the rights to make a decisions on important affairs of the company. However, the shareholders have the right to vote at meeting according the number of shares owned by each shareholder, whereby one share is for the one vote as following action.

1. Disclose the important information and necessary for shareholders regarding the company's business via The Company's website and Stock Exchange Market of Thailand's system.
2. Send the meeting invitation containing the date and the agenda of the meetings and relevant documents for all shareholders completely with the full details of meeting venue, details of each item in the meeting, annual report, proxy statement and independence committee information. In case of the shareholders are unable to attend the meetings, they are entitled to appoint a representative to act as their proxy, using the proxy forms attached to the notice of the meeting.

3. Disclose significant and sufficient detailed information of the agendas of meeting 30 days in advance. This will be posted on the Company's website in order to all shareholders have an opportunity to acknowledge all information before the meeting.
4. Before the meeting, the chairman must clearly inform the shareholders the number of shareholders which is included in the proxy form, then demonstrate how ballots are cast and counted the result of the vote; hence consist of the independence committees, the auditors and The Company's staffs for transparency calculation and will show the result of vote in each agenda.
5. At the meetings, the shareholders are allowed to freely express their opinions, give suggestions and raise questions on any agenda before calling for a vote on a resolution. Should shareholders have questions on any agenda issues, specialists in the specific fields are available to answer those questions under the responsibility of the Board.
6. The Company gives shareholders who show up late a chance to vote on agenda item still under deliberation.
7. All directors attend each shareholder's meeting, and all shareholders are allowed to raise questions to the chairman of each committee on any matters.
8. The company conducts its business efficiently for its growth and returns to shareholders appropriately.

#### **Item 2 : Equitable Treatment of Shareholders**

The company realizes all shareholders; both of major and minor are valued and treated as equally and fairly. As following actions;

1. The Company gives all shareholders a chance to suggest the additional agenda items and propose the name of person who is appointed as annual general meeting's committee before sending meeting invitation. Hence, the Company must inform the details and timeline of the right via Stock Exchange Market of Thailand's news system.
2. The meeting will be run on each agenda items respectively according to the meeting invitation and no the additional items besides of the meeting invitation.
3. To provide shareholders with a list of all Independent Directors on proxy form in order to have an option to appoint any Independent Directors as their proxies and to encourage them to use proxy form that allow balloting direction.
4. To prepare the ballot in each agenda issues for all shareholders in voting especially, for the shareholders who are disagree and no vote with any agendas in order to the shareholders are able to freely express in any agendas and also check the resolution when finish the meeting.
5. Giving all shareholders a chance to have an option on their own voting to select the Independent Director individually.

6. The company defines the way of confidential information retention as well as the prevention of insider trading as part of GCG practices and the Code of Business Conduct. Thus, the Board, top executives and all employees must adhere to in practice in order to protect any effective matters with the company.
7. To conduct action role for the committee, Board of executive and all employees regards to conflict of interest in the company's code of conduct in order to treat the fair of advance.

### **Item 3 :Roles of Stakeholders**

The Company has defined the equitable treatment policy to every group of stakeholder: for instance, individual shareholders and investors, customers, suppliers and/or lenders, business competitors, employees, government and community and public in accordance with the rights of The Company's code of conduct and corporate governance in order to build the cooperation between the Company and all stakeholders, making benefit, sustainable finance and its business.

#### **Treatment for the stakeholder**

##### 1. Shareholders and Investors

The Company has policies on business operations, adheres to the practiced principles defined by ethical framework and effort to improve constant growth of business, good result in order to make a suitable and sustainable benefit for shareholder's investment and all investors as continually and sustainable with adhering to the adequate treatment towards all shareholders.

##### 2. Customers

Recognizing of the customer satisfaction is the most important, hence the company has brought ISO 9001:2008 standard using in its company. Moreover, the company has also conducted the quality policy as **"Steel Intertech Public Company Limited is committed to delivery of quality and standard products to our customers with continuous improvement and highest customer satisfaction basis"**.

##### 3. Suppliers and/or lenders

The company has policies to keep good relations with suppliers and/or lenders in term of business which is based on fair, and treats all its suppliers and/or lenders equally for the maximum benefit of company and avoiding the situation of conflict of interest, including strictly follows promises in order to mutually reach benefit.

##### 4. Competitors

The company treats its competitors based on a competitive context as fairly. No seeking for the confidential information of competitors as dishonestly or improperly.

##### 5. Employees

The company realized the importance of employees that are most valuable assets, being one part of encouraging to achieve business goal. It is, therefore, STEEL has policies to take care its employees to have a good quality of life, also places emphasis on fair employment, proper welfare, improve their skill and working in safety and sanitation.

6. Government

The company operates its business in order to improve and develop the growth of country, stipulated by the law, rule and related regulation, along with business traditional.

7. Community & Public

The company operates its business under responsibilities for communities and society. In addition, the company emphasizes to contribute continuously to the public benefit of society as well as concern in safety standard, good health, appropriate environment and effectiveness.

**Item 4: Information Disclosure and Transparency**

The company realizes the importance of information disclosure which are related company, both financial information and non-financial information. Information disclosed via the SET Community Portal and STEEL's website shall be accurate, complete, up to date and reliable, written both in Thai and in English for instance; annual meeting report, 56-1 form, invitation letter and shareholders meeting report.

The company is committed to obeying the law, regulations and obligations mandated by the Securities and Exchange Commission (SEC), SET and other related government sectors, for example:

1. Financial disclosure, in particularly financial statement must be completed and comply to generally accepted accounting standard, by auditing from independent audit committee that timely financial information along with approved by the Audit Committee and the Board of Directors before disclose to public.
2. Require the company's directors and executives to disclose their interests in connection with those of STEEL and the persons involved in the company's interests.
3. Disclose the role and duty of the committee and sub-committee, meeting record and attendance record of each member of the committee in annual report.
4. Disclose the policy on remuneration of the directors and the top executives, including forms, types and amount of remuneration for each member of the committees.

**Item 5 : The Responsibilities of the Board**

**1. Structure of the Board of Directors**

The Board of Directors comprises of the persons who are accepted knowledgeable and competent, moreover, responsible for drawing up corporate policy and collaborating with the top executives in making the

operating plans both short term and long term plans. In addition, the Board shall be responsible to draw up financial policy, risk management policy and the organization overview. The Board shall play an important role in overseeing, monitoring and assessing the performance of the company and the top executives on an independence basis.

Presently, the company has fixed an appropriate number of directors as 7 which comprises 4 executive directors and 3 non-executive directors, who are independent directors. The independent directors must be independent of others and must not being stakeholder, no relationship with major shareholder neither being an executive nor representative of major shareholder.

## **2. Sub-committee**

The Board of Directors has appointed the sub-committees as following committees, Audit Committee, Corporate Governance and Nomination Committee and Remuneration Committee, to be responsible to their specific areas and report directly to the Board for its consideration.

2.1 The Audit Committee comprises 3 independent directors, those comprises at least one-third independent directors or not less than 3 directors constantly. The Audit Committee's qualification is required by SEC's regulation as following areas;

- (1) The Audit Committee who owns not over 5% of the total shares eligible for voting of the company, parent company, subsidiary, associated company or person with probable conflict of interests.
- (2) Not being an employee, staff, advisor or authorized person of the company, parent company, subsidiary, associated company or person with probable conflict of interests.
- (3) The committee who has no family relationship in a manner as parents, spouses, brother and children, including associated child's spouse or legitimate relationship with authorized person of the company, parent company, subsidiary, associated company or person with probable conflict of interests.
- (4) The committee who has no business relationship with the company, parent company, subsidiary, associated company or person with probable conflict of interests in the manner that may jeopardize independent judgment.
- (5) The committee who possesses no other qualify that may jeopardizes expression of independent opinions about the company business.

The Audit Committees has duties to monitor and transparency in financial reports disseminated to the public, proposing nomination of external auditors and top executive who is responsible, including internal control and internal audit and risk management concisely, appropriately and up to date and efficiency. Those are audited by BK Audit and consultant which is responsible in internal monitoring and directly report to Board of Directors.

2.2 Nominating and Remuneration Committee comprises 3 directors, Roles of the Nominating and Remuneration Committee are to help the Board and shareholders on evaluating its own performance and report it to

the Board annually, including considers and proposes structure of remuneration for directors and executives ,i.e. salary, severance pay, bonus, welfare, meeting allowance, and other fringe benefits. The remuneration payment method is considered by structure as fairly and reasonably.

2.3 The Executive committee is 5 persons, comprises concerned Board of Directors 4 persons and 1 which is non-Board of Directors. The executive committee is responsible to plan and devises policies, directions, strategies, plan, budget, organization structure and management structure. The business operation must be rooted in and consistent with economic situation and competitive situation, and submit to the Board of Directors to consider and and/or approve, including monitoring and evaluating the results in accordance with company's policies.

### **3. Roles and Responsibilities of committee**

The Sub-committees duties in accordance with the law, the objects and regulations of the Company as well as he resolution of the Meeting of Shareholders, with approve of laws, honest and carefulness in the fringe benefits of the company. The Authority and Responsibilities of Sub-committee are as following areas;

3.1 The Board of Directors always adheres to criteria, method and disclosure of a inter transaction, as laid down by the Stock Exchange of Thailand, for the maximum benefits of the Company and shareholders and for sake of transparency of those transactions.

3.2 Define targets, business directions, policies, business plan and annual budget for the company, and other matters as assigned by the Board, exceptional some duties has been authorized by the shareholder meeting for instance ; capital increment, capital reduction, debentures, selling and take over the business, revising of Memorandum of Association and Articles of Association or regulations i.e.

3.3 Consider management structure, appoint the management committee, president and other sub-committee as properly.

3.4 Following up results in accordance with implement plan and company's budget continually.

3.5 Hold the annual general meeting of shareholders within 4 months since the fiscal year end.

3.6 Prepare the balance sheet and income statement at the end of fiscal year, submitting to the meeting of shareholders for consideration and approval.

3.7 The director of operations may not have the same conditions as well as competition with company's affairs, in ordinary partnership or a limited partnership. Liability of limited partnership, a director of a private company, a limited partnership or other operations, whether to make its own interest or other interest. But exceptional will notify the shareholders before eligible resolution.

3.8 Whether being stakeholder in contract directly or not, including holding share or both increased debentures or decreased in company and corporate company. The committee must inform the company immediately.

#### 4. Boards Meeting

It is the duty of a member of the Board to constantly attend the Board's meeting to acknowledge and together make decisions on business operations. The Meeting of the Board of Directors is held at least once every three month and in each meeting, agendas of meeting are predetermined in advance. In addition, the Board may urgently call for an extraordinary meeting of shareholders anytime.

At the meeting, the Chairman and the President of the company jointly determine on which items on agendas are relevant to the meeting. Every individual members of the Board is entitled to propose the agenda items. In each meeting, accompanying document are sent to each director in advance so that they would have enough time to study and consider it.

When considering the matter agendas presented to the Board, Chairman of the Board presides over and duly conducts the meeting. All members of the board are allowed to express their freely opinions. Resolution is passed with a majority vote, providing that one director is eligible for one vote. The director with any interest in the issue under consideration or the director ineligible to vote is excused and to be absent during vote. In case of a tie vote, chairman of the meeting will vote and give the binding result.

In the Board's meeting, the management is encouraged to attend the meeting to provide updated information to the Board, and to acknowledge policies directly for effective implementation.

After the meeting, the secretary to the Board is responsible for preparing the minutes, and sending the certified copies to the directors. The minutes must be approved at the following Board's meeting and certified by Chairman. In addition, the directors may make comments, corrections, or additions to ensure the greatest accuracy and completeness.

#### Board of Directors' Meeting Attendance Statistics for the year 2010

Name	Position	No.	No.	No.	No.	No.	No.	No.
		1/2010	2/2010	3/2010	4/2010	5/2010	6/2010	7/2010
Dr. Suradej Chuntranuluck	Chairman of Board of Director and Chairman of Audit Committee	✓	✓	✓	✓	✓	✓	✓
Mr. Prasit Ounvorawong	Committee	✓	✓	✓	✓	✓	✓	✓
Ms. Sureerat Thongbri	Committee	✓	✓	✓	✓	✓	✓	✓
Mr. Supote Wannarote	Committee	✓	✓	✓	✓	✓	✓	✓
Mr. Somchai Vongratanavichit	Committee	✓	✓	✓	✓	✓	✓	✓
Mr. Lertchai Wongchaiyasit	Audit Committee	✓	✓	✓	✓	-	✓	✓
Mr. Numpon Ngurnnumchoke	Audit Committee	✓	✓	✓	✓	✓	✓	✓

## **5. Remuneration for the Board and the Management**

The Company appropriately sets remuneration for members of the Board and top executives at rates comparable to those of other top companies in the same industries. The remuneration for top executives is set by the Board of Directors, based on their responsibilities, performance and the operating results of the company.

In addition to basis remuneration, the company sets yearly bonuses and variable payments for the directors according to guidelines approved by shareholders' meeting, and the payments for the top executives is based on their performance and the operating results of each business. The remuneration payment method correlates with the employees, performance, thus reflecting the company's operating results.

## **6. Performance Appraisal and Knowledge Enhancement**

To enhance capabilities of the Board's and the Committee members, the company encourages and makes a convenient for all members who related in corporate governance management such as committees, the Boards and the top executives to attend various training and course benefited in order to find the ways for continual improvement the Board's performance.

In the case of changing the new directors, the company prepares a booklet for members of the Board, which includes the rules and regulations related the directors, including guidelines of business operations. The booklet is distributed to all current and new directors, for their basic information.

### **5.6 Measures Against Illegal Use Of Confidential Information**

The company devises policy and sets verification procedures against illegal use of material internal information undisclosed to the public by directors and members of the management of their personal interest in securities trading as follow:

1. Directors and members of the management are informed of requirements and obligations made to them, their spouses and dependent sons/daughters to report their securities ownership to Office of Securities and Exchange Commission and the Stock Exchange of Thailand pursuant to Section 59 and its penalty, and Section 275 of the Securities and Exchange Act B.E. 2535.
2. The management is required to report any changes made to their securities ownership to the Office of Securities and Exchange Commission and the Stock Exchange of Thailand pursuant to Section 59 of the Securities and Exchange Act B.E. 2535. Such report must be made through the company in order to allow complete verification of securities ownership of each management member.
1. The Company shall send circulation letter to members of the management to notify that, should they have access or acknowledgement to material internal information sensitive to change in share prices, their securities trading is not allowed within the period of one month prior to the disclosure of financial statements to the public and they are not allowed to leak such material internal information to the outsiders or other unauthorized persons. In case of illegal use of such material internal information by members of the Board of Executive Directors, which can adversely affect the company or shareholders, the Board of Director shall consider

applying appropriate penalties against such breach. Board of Directors is responsible for application of penalties for any breach conducted by management of lower hierarchy.

### 5.7 Evaluation of internal controlling system

In Board of Director's Meeting no.2/2011, held on February 28, 2011, there are the audit committees participated this meeting. The committees have evaluated controlling system by inquiry regarding information from the executives and the independent audit committee, BK Audit and consultant. Regarding to sufficiency evaluation of controlling system of 5 components are organization and environment control, risk assessment, performance control, information and communication, and monitoring and evaluation. After evaluation process, the boards have agreed that the company has the sufficient internal control systems especially, the internal control systems of 5 components which appropriating and adequate in order to protecting of corrupting or unauthorized from management, including of the independent internal audit for follow up and evaluation. In addition, the company has confidential documentation that the committees, the accountant audit and authorized person enable to monitor in period of time appropriately.

At the present, the company has no its own internal audit department. By the way, the company hired BK Audit and Consultants (office) to be in charge an internal audit, giving a recommendation of reviewing the internal control, create internal audit plan including internal audit proceeding by submit the result to the audit committee directly in order to enhance in efficiency through monitoring and evaluation pursuant to the Audit Committee's recommendation.

The audit committee's meeting no.2/2011, concluded internal audit result which approve of internal audit evaluation are as follow;

1. **Control Environment** - To specify implementation of policies, together with clearly document, providing discipline or expected standard for employees in order to do following the ethical behavior.
2. **Risk Assessment** – No risk evaluation criteria or moderated guidance of risk in order to be a criteria as obviously.
3. **Control Activities** – Control activities must be established as the company target in order to following as ISO criteria, but there is no consideration consistent risk level.
4. **Information and Communication** – Providing report and information retrieval for some department is still problem, or unable to support whole requirement and database also is unable to connect the system. Hence, it must additional generate.
5. **Monitoring and Evaluation** – The Boards of Director meeting is regularly held in order to continuously monitor the company activities.

The conclusion of internal controlling system evaluation - internal control system of the company at February 28 , 2011, the level of internal control is moderately. However, there are some flaws in particularly risk assessment should be improved and ensure that all parties in order to achieve its overall target.

## **5.8 Remuneration for Independent Auditor**

### **5.8.1 Auditing Remuneration**

During the past year, the company paid auditing remuneration to auditing firm where independent auditor is attached to, person or entity related to independent auditor and accounting firm where independent auditor is attached at the total amount of 540,000 baht.

### **5.8.2 Other Charges**

-- None --

## Board of Directors and Executive Profiles

Name-Last Name ID Card No.	Age (Year)	Academic Background	Family Relationship with the Management	% shareholding	Work Experience for the past 5 years			
					Period	Position	Organization Name / Company	Type of Business
Dr. Suradej Chuntranuluck	64	- BS (Engineering) (Hon.), Chulalongkorn University - MSCE University of Minnesota - PH. D. University of Minnesota - IDO Certification, DAP 31	None	-	2004 – Present	Chairman and Chairman of Audit Committee	Steel Intertech Plc.	Manufacture, distribution and installation of roll forming metal sheet products, and roof & wall related products
					1989 – Present	Chairman and Managing Director	Citania Company Limited	Engineering Consultant
Mr. Prasit Ounvorawong	51	- BS (Mechanical Engineering) King Mongkut's Institute of Technology North Bangkok - MBA, National Institute of Development Administration - IDO Certification, DAP 31 - Public Management & Law 7, King Prajadhipok's Institute - CMA 9, Capital Market Academy - Public Administration and Law for Executives 14, King Prajadhipok's institute.	None	26.30	1995 – Present	Director and Managing Director	Steel Intertech Plc.	Manufacture, distribution and installation of roll forming metal sheet products, and roof & wall related products
Mr.Supote Wannarote	52	- BS (Civil Engineering) King Mongkut's Institute of Technology North Bangkok - MBA, Kasetsart University - IDO Certification, DAP 72	None	4.17	2007 – Present	Director and Executive Director and Vice president Sales and Marketing	Steel Intertech Plc.	Manufacture, distribution and installation of roll forming metal sheet products, and roof & wall related products
					1997 – 2007	Advisor/Consulting	Engineer	Construction
					1989 – 1997	Construction Manager	Budharut Co., Ltd.	Construction
					1989 – 1991	Project Manager	Srusuwan Yosha Ltd.,Part	Construction

Name-Last Name ID Card No.	Age (Year)	Academic Background	Family Relationship with the Management	% shareholding	Work Experience for the past 5 years			
					Period	Position	Organization Name / Company	Type of Business
Ms. Sureerat Thongbri	39	- BBA, Bangkok University - IDO Certification, DAP 31	None	-	2004 – Present  2010 – Present  1995 – 2004	Director and Executive Director Executive Director and Administration Director Purchasing manager	Steel Intertech Plc.	Manufacture, distribution and installation of roll forming metal sheet products, and roof & wall related products
Mr. Somchai Vongrattanavichit	50	- B.E. (MECHANICAL ENGINEERING) RMIT UNIVERSITY (Royal Melbourne Institute of Technology) - MBA, Kasetsart University - IDO Certification, DAP 43	None	0.88	2005 – Present  1995 – Present  2004 – 2548 2004 – 2548 2001 – 2003 1995 – 2001	Director and Executive Director  Director Director Factory Manager Director and Factory Manager	Steel Intertech Plc.  Kijcharoen Plastic Industry Co., Ltd.  Wide Connect Co., Ltd. All Link Company Limited Hua Thai Manufacturing Pls. Kijcharoen Plastic Industry Co., Ltd.	Manufacture, distribution and installation of roll forming metal sheet products, and roof & wall related products Manufacture and Distribution of Color Pellet for Plastic Production Distribution of Computer Appliances Distribution of Computer Appliances Manufacture and Export Garments Manufacture and Distribution of Color Pellet for Plastic Production
Mr. Numpon Ngurnnumchoke	42	- BS (Mechanical Engineering) King Mongkut's Institute of Technology North Bangkok - MBA, Kasetsart University - IDO Certification, DAP 31	None	-	2011 – Present 2009 – Present 2004 – Present  1992 – 2010 2010 –Jan,2009  2003 –Jan,2009 2006 – 2008  2004 – 2006 2004 – 2006	Director and Audit Committee Director Director and Audit Committee  General Manager Director and Managing Director Director Director and Chairman of Audit Committee Managing Director Senior Vice President	J.S.V. Hardware Co., Ltd. Pinic Corporation Plc. Steel Intertech Plc.  Ngurnnamchoke Group Co., Ltd. Power – P Plc.  Wealthsprout Corporation Co., Ltd. Pinic Corporation Plc. G. E. C. Property Co., Ltd. Saim Nara Engineering & Consulting Co., Ltd.	Manufacture,distribution of conduit Retailing in Liquid Petroleum Manufacture, distribution and installation of roll forming metal sheet products, and roof & wall related products Retailing of Gift and Souvenirs Manufacturer , construction material and pre- stress concrete pile Commercial Consulting Retailing in Liquid Petroleum Real Estate Development Construction and Engineering Consultant

Name-Last Name ID Card No.	Age (Year)	Academic Background	Family Relationship with the Management	% shareholding	Work Experience for the past 5 years			
					Period	Position	Organization Name / Company	Type of Business
Mr. Lertchai Wongchaiyasit	46	- Diploma of Operation Management, National University of Singapore - IDO Certification, DAP 31	None	-	2004 – Present  1995 – Present	Director and Audit Committee  Managing Director	Steel Intertech Plc.  J.S.V. Hardware Co., Ltd.	Manufacture, distribution and installation of roll forming metal sheet products, and roof & wall related products  Manufacture, distribution of conduit
Mr. Chaiwat Tungsuwanpanit	50	- BA, Chulalongkorn University - MBA, Thammasat University - IDO Certification, DAP 31	None	-	2007 – Present  2005 – 2007  2004 – 2005  2003	Vice president Accounting  General Manager in Accounting  Managing Manager  Accounting Controller	Steel Intertech Plc.  Premier Steel Processing Co, Ltd  River Engineer Co, Ltd  Bangkok Rant Plc.	Manufacture, distribution and installation of roll forming metal sheet products, and roof & wall related products  Distribution of all kind of steel  Distribution of water pump  Manufacture, distribution and export fresh duck and freeze duck.
Mr. Kanoksak Piamnitikorn	37	- BS, King Mongkut's Institute of Technology Thonburi - MBA, Bangkok University	None	-	2006 – Present  2005-2006  2002-2005  1998-2002  1995-1998	Production Manager  Business Development Manager  Business Development Manager  Sales / Production / Engineering Manager  Production Manager	Steel Intertech Plc.  Business Care Service Co., Ltd.  Supplier Connex Ltd.  AGS Auto Parts Co., Ltd.  Thai Radiator Mfg. Co., Ltd.	Manufacture, distribution and installation of roll forming metal sheet products, and roof & wall related products  Software Development and Distribution of Computer Appliances  Organization Data Base Management and e-catalog  Vechicle Manufactureing and Molding  Manufacture Vehicle Spare Parts e.g. Radiator, Gasoline Tanks and Steel Sheet Molding
Mr. Sanith Aroontaveesub	42	BBA, Sukhothai Thammathirat University	None	-	2009 – Present 1997 - 2009	Installation Manager Installation Section Manager	Steel Intertech Plc.	Manufacture, distribution and installation of roll forming metal sheet products, and roof & wall related products

Name-Last Name ID Card No.	Age (Year)	Academic Background	Family Relationship with the Management	% shareholding	Work Experience for the past 5 years			
					Period	Position	Organization Name / Company	Type of Business
Mrs.Nongnuch Meesuk	34	- BBA, Rangsit University	None	-	2010 – Present	Human Resources Manager	Steel Intertech Plc.	Manufacture, distribution and installation of roll forming metal sheet products, and roof & wall related products
					2009 – 2010	Asst.HR & Administration Department Manager	Yamakho Precision (Thailand) Co.,Ltd.	Manufacture plastic spare part for electrical appliance.
					2008 – 2009	Payroll	Bangkok Hospital	Hospital
					2005 – 2008	HR & Admin	Taisei (Thailand) Co.,Ltd.	Construction

## 6. Inter Company Transactions

### 6.1 Inter company transactions as a result of Organization Restructuring

On September 30, 2004, Steel Intertech (Public) Company Limited underwent organizational restructuring through disposal of the company's 30% investment valued 624,000 baht or 208 baht book value per share, based on financial report from the management at the end of August 2004, in Steel Intercon Company Limited to Mr. Nat Whangmahaporn, who is a shareholder. At the time, of such investment disposal, Steel Intercon Company Limited was discontinued its operations. Therefore Mr. Nat Whangmahaporn only acquired the shares for purpose of business dissolution. However, in 2004, the company made an adjustment o income realization method in proportion to work delivery percentage. In doing so, independent auditor adjusted fiscal year 2003 items related to service income realization, corporate income tax and retained earnings. Fiscal year 2003 retained earnings were resultantly lowered by 542,193.77 baht and carried forward to fiscal year 2004 realization. Therefore, book value per share as of September 30, 2004 was adjusted at 237 baht, which was higher than the value earlier estimated by the management. Consequently, the company realized the loss 86,995.14 baht from the disposal of the investment. Such loss was presented in fiscal year 2004 financial statements.

#### Opinions of Audit Committee

During the Audit Committee Meeting No. 1/2005, held on March 25, 2005, Audit Committee acknowledged the said organizational restructuring and opinions that Steel Intercon's shares were disposed to a shareholder who was neither director nor management member of Steel Intercon and that the transactions was reasonable at the time when it was made. Audit Committee further opined that such organizational restructuring, enhanced our management efficiency and was solely intended for the benefit of the company business operations.

No transactions occurred during in 2007-2010

### 6.2 Inter Transaction Approval Procedures/Measures

In entering into inter transaction, Board of Directors shall review the transactions and consider approval within authorized authority and responsibilities. Future inter transactions are subjected to consideration by Audit Committee to preserve our best interests and to protect shareholders and all concerned parties against lost interests. Inter transactions are subject to be in compliance with relevant stock exchange legislation, regulations, notifications, orders or requirements issued by the Stock Exchange of Thailand. Those persons with probable conflict of interests or vested interests in any inter transactions are not allowed to participate in considerations and votes for the issue.

### 6.3 Inter Transaction Trends/Policy

In reference to future inter transactions, they are required to be in line with our general business nature and free from unfair interest allocation among shareholders, board members, or concerned parties. Audit Committee and/or Board of Directors is responsible for considering necessity and appropriateness of each inter transaction as well as ensuring pricing and entering conditions in line with our general business nature. Those persons with probable conflict to interests or vested interests in any inter transactions are not allowed to participate in consideration and votes for the issue. Board of Directors

shall handle inter translation in compliance with relevant stock exchange legislation, regulations, notifications, orders, or requirements issued by the Stock Exchange of Thailand. Such handling of inter transactions by Board of Directors shall be also in compliance with requirements governing the disclosure of inter transactions, acquisition and disposition of assets by listed company and its subsidiaries as required by the Stock Exchange of Thailand. Furthermore, handling of inter transactions has to be in compliance with accounting standards set by the Institute of Certified Accountants and Auditors of Thailand. In case of any inter transactions with those persons of probable future conflict of interests or vested interests; we shall seek opinions from Audit Committee for necessity and appropriateness of such transaction and for conformity with our general business nature. Opinion sought from Audit Committee also includes price determination in comparison with current market price. In the event that Audit Committee has no expertise in any inter transactions, we shall seek opinions from external independent specialist or our appointed independent auditor. Based on their independent opinions Board of Directors or shareholders for final decision, as the case may be, shall make final decision on the issue. Information on inter transactions is subject to disclosure in notes to audited financial statements.

## 7. Management Discussion and Analysis

### Fiscal Year 2008 – 2010 Operational Results

#### Revenue

The company revenue in fiscal year 2008, 2009 and 2010 were equal to 360.12 millions, 293.12 millions and 311.44 millions baht respectively, represent decreasing to 18.60 comparing to year 2008 and increasing to 6.25% comparing to year 2009 respectively. The revenue of company in year 2010, grew up from year 2009 because of gross profit margin increment, caused by Thai baht currency strong rapidly, resulting public sector has started investing in fixed assets

The revenue structure in fiscal year 2008, 2009 and 2010 are classified as follow:

Revenue Structure	Financial Statement					
	Year 2008		Year 2009		Year 2010	
	Valued (Thousand Baht)	%	Valued (Thousand Baht)	%	Valued (Thousand Baht)	%
1. Revenue from sales	223,173.80	61.42	148,316.25	50.14	145,105.14	45.88
2. Sales and Installation	136,947.42	37.69	144,810.43	48.96	166,330.22	52.60
3. Installation Services	-	-	-	-	-	-
4. Other Revenues	3,253.32	0.90	2,649.22	0.90	4,819.07	1.52
<b>Total Revenues</b>	<b>363,374.54</b>	<b>100.00</b>	<b>295,775.90</b>	<b>100.00</b>	<b>316,254.44</b>	<b>100.00</b>

Other revenues derived from selling of metal scraps, transportation and others.

#### Cost of Selling and Administration Expenses

#### Cost of Goods Sold and Gross Profit Margin

Our cost of goods sold in fiscal year 2008, 2009 and 2010 were equal to 295.12 millions, 248.77 millions and 255.24 million baht respectively, which are 81.22%, 84.11% and 80.71% respectively in comparison with the total revenue. The major cost came from raw materials form BlueScope Steel, which are 86.01%, 86.33% and 89.27% of total cost in fiscal year 2008, 2009 and 2010 respectively.

Cost Structure and Gross Profit Margin are divided into 3 categories as follow:

(1) Cost of goods sold: In fiscal year 2008, 2009 and 2010 were equal to 181.08 millions, 127.42 millions and 123.24 million baht respectively. The figures represented annual gross profit margin of 18.86%, 14.09% and 15.07%

respectively. In year 2008, the gross profit margin grown up because of fluctuation of raw material price, resulting the customer made a quick decision on purchasing during the middle of fiscal year. After that, in Q4 of year 2009, the gross profit went down because of the rapidly decreasing price of raw material that made company had to reduce the selling price to meet the customer needs. In year 2010, the gross profit margin grew up resulting from the rapid strong baht that public sector start investing in fixed assets.

(2) Cost of goods sold and installation: In fiscal year 2008, 2009 and 2010 were equal to 114.04 millions, 121.35 millions and 132.01 million baht respectively. The figures represent annual gross profit margin of 16.72%, 16.20% and 20.64 % respectively. The instability of gross profit margin from cost of goods sold and installation, caused by direct sales to contractors and owners through project bidding, making the profit vary from project to project.

#### Cost of Sales and Administration Expenses

In 2008, Cost of Sales and Administration Expenses was 40.11 millions, which is 11.04% to total revenue or 15.93 % increase from 2007. Part of the expenses was from the increase in doubtful debt reserved fund, which increase to 3.17 million baht.

In 2009, Cost of Sales and Administration Expenses was 39.99 millions, which is 13.52% to total revenue or 0.31 % decrease from 2008. Part of the expenses was from increase in fund reserved to doubtful debt to be 1.49 million baht.

In 2010, Cost of Sales and Administration Expenses was 47.02 millions, which is 14.87% to total revenue or 14.95 % increase from 2009. Part of the expenses was from increase in fund reserved to doubtful debt to be 1.59 million baht.

#### Net Profit

In fiscal year 2008, 2009 and 2010, the company had the net profit of 20.17 millions, 3.70 millions and 8.97 million baht, represented decreasing to 81.64% and increasing to 142.28%. In 2008, the net profit grew up due to the customer had its more projects. In addition, due to the fluctuation of raw material price that made the most customer accepted to buy higher price. However, the customer slows down on purchasing due to the prices adjusted down in the end of year 2008. In year 2009, net profit sharply went down due to the subprime mortgage segment of the United States in the end of year 2008 impacted to overall market has decelerated, together with a high fluctuation steel price on the beginning of year 2009. In year 2010, the net profit grew up due to domestic economic recovery in according to the world economy in additional resulting from Strong Thai project.

**Financial Status****Financial Structure Table**

Items	2008		2009		2010	
	Thousand Baht	%	Thousand Baht	%	Thousand Baht	%
Current Assets	112,636.67	55.36	107,415.46	55.93	76,902.95	47.14
Non-Current Assets	90,818.75	44.64	84,626.59	44.07	86,237.39	52.86
<b>Total Assets</b>	<b>203,455.42</b>	<b>100.00</b>	<b>192,042.05</b>	<b>100.00</b>	<b>163,140.34</b>	<b>100.00</b>
Current Liabilities	84,482.85	41.52	92,938.15	48.39	60,371.66	37.01
Non-Current Liabilities	17,510.59	8.61	12,435.95	6.48	9,627.32	5.90
<b>Total Liabilities</b>	<b>101,993.44</b>	<b>50.13</b>	<b>105,374.10</b>	<b>54.87</b>	<b>69,998.98</b>	<b>42.91</b>
Shareholder's Equity	101,461.98	49.87	86,667.95	45.13	93,141.36	57.09
<b>Total Liabilities and Shareholder's Equity</b>	<b>203,455.42</b>	<b>100.00</b>	<b>192,042.05</b>	<b>100.00</b>	<b>163,140.34</b>	<b>100.00</b>
Debt to Equity Ratio (Times)	1.01		1.22		0.75	

**Assets**

Our total assets at the end of fiscal 2008, 2009 and 2010 were reported at 203.45 millions, 192.04 millions and 163.14 million baht respectively, which represented annual decreasing rates to 5.61% and 15.05% respectively. There were changes in major current assets, which were trade account receivables in fiscal 2008, 2009 and 2010 amounted to 40.71 millions, 37.68 millions and 31.80 million baht respectively, which represented annual decrease of 7.44% and 15.60% respectively. In addition, the decreasing of inventory in year 2008, 2009 and 2010 were 47.35 millions, 41.04 millions and 20.27 million baht respectively, represented decreasing to 13.33% and 50.61% respectively.

Operation cash flow fiscal year 2008, 2009 and 2010 has been positive with the amount of 10.93 millions, 4.60 million and 40.03 million baht respectively. The changes in cash flow came from (1) decrease in trade account receivable from purchasing of raw material in fiscal year 2009 and 2010, with the amount of 3.93 millions and 13.05 million baht respectively, (2) increase pre-income in fiscal year 2009 and 2010 amounted to 12.85 millions and 8.46 million baht respectively from early completing jobs, (3) cash and deposit at Financial institutions in total are 13.27 millions, 4.80 millions and 10.87 million baht in fiscal year 2008, 2009 and 2010 respectively. In 2008, the dividend was 15.0 million baht. In 2009, although the overall market was decelerated, the dividend was 18.49 million baht. In 2010, the economic was recovery in the end of year, the dividend was 12.49 million baht.

**Asset Quality****Trade Account Receivable**

Our net trade account and net receivables at the end of fiscal year 2008, 2009 and 2010, equal to 40.71 millions, 37.68 millions and 31.80 million baht respectively.

We set a reversed provision for doubtful debts based on estimated default value, especially from those trade account receivables with average age longer than 6 months to 12 months and over. The amount of reserve for doubtful debts is estimated through previous transaction records of each trade account receivable. At the end of fiscal year 2008, 2009 and 2010, our allowance for doubtful debts were 11.62 millions, 13.11 millions and 15.70 million baht respectively, which represented annual increases of 12.82% and 19.76% respectively.

Based on our corporate policy, we provide our trade account receivable with 30-45 days for settlement. As for trade account receivable incurred from sales and installation package, we have a policy to demand immediate settlement because of as usual nature of longer settlement period for this sale category. In the past, sales and installation package required settlement period of between 45- 60 days.

The company's average ability to correct debt in fiscal year 2008, 2009 and 2010, equal to 60 days, 80 days and 74 days respectively. In 2008, the company began more stricter with credit, resulting to be in average standard. In 2009, due to the tight of financial market, the average ability was over standard between 30-60 days. In 2010, due to economic was recovery, the company again more strict with credit.

**Liquidity**

Net cash flow from operation in fiscal year 2008, 2009 and 2010 have been in positive with the amount of 10.93 millions, 4.60 millions, and 40.03 million baht respectively, caused from (1) decrease in commercial creditor in fiscal year 2009 in comparison with year 2008, decreasing to 3.93 million baht and in year 2010 comparing to year 2009, decreasing to 13.05 million baht. (2) increase in advance revenue in fiscal year 2009, equal to 12.85 million baht due to the early completion of the projected and in 2010 there were incomplete project value 8.45 million baht.

Net cash spent on financing activities fiscal year 2008, 2009 and 2010 equal to 10.80 millions, 0.79 millions and 0.43 million baht respectively

In year 2008, dividend of operation in fiscal year 2007 was 7.50 million baht and the interim dividend in fiscal year 2008 equal to 7.50 million baht. In year 2009, the company has paid dividend of operation in fiscal year 2008 amounted 6.0 million baht and the interim dividend twice times equal to 2.50 millions and 9.99 million baht respectively. In 2010, the company has paid the interim dividend from earning was 2.50 million baht.

**Source of Fund****Shareholder's Equity**

Shareholder's Equity at the end of fiscal 2009 and 2010 equal to 86.67 millions and 93.14 million baht respectively, which accounted for an annual increase of 7.47%. In 2009, the company had its operation with the net profit of 3.70 millions and dividend was 18.49 million baht. In 2010, the net profit was 8.98 million baht and dividend was 2.5 million baht.

**Liabilities**

Our total liabilities at the end of fiscal year 2008, 2009 and 2010 were 101.99 millions, 105.37 millions and 69.99 million baht respectively, represented an annual increase of 3.31% and decreasing to 33.58% respectively. Major contributing factors for such changes were (1) changes in current liabilities at the end of fiscal year 2008, 2009 and 2010, were 84.48 millions, 92.93 millions and 60.37 million baht respectively, represented an annual increase of 10.00% and decrease of 35.04% respectively. In year 2008, the accountable payable decreased from 61.92 million baht in fiscal year 2007 to 54.63 million baht. In year 2009, the debt decreased by 4.14 million baht to 50.48 million bath and year 2010, the debt still decreased by 13.05 million baht to 37.43 million baht.

We have warranty commitment for product and service delivered to our customers under the condition of the damages and faults caused by products only, not other damages and faults as results of external factors. Warranty period lasts approximately between 1-30 years. The management, however, is convinced that no significant liabilities are incurred due to the warranty commitment because our authorized dealers also offer warranty under the same conditions with warranty period between 5-30 years, thereby enabling us to demand indemnification from dealers throughout warranty period. Therefore, we do not realize expenses and liabilities in connection with the warranty commitment. However, we still have liability commitment due to bank guarantee at the amount of 1.15 million baht at the end of fiscal 2010.

INDEPENDENT AUDITOR'S REPORT

To the Shareholders and Board of Directors of **STEEL INTERTECH PUBLIC COMPANY LIMITED**.

I have audited the accompanying balance sheets as of December 31, 2010 and 2009, and the statements of income, the statements of changes in shareholders' equity and the statements of cash flow for the years then ended of **STEEL INTERTECH PUBLIC COMPANY LIMITED**. These financial statements are the responsibility of the company's management as to their correctness and completeness of the presentation. My responsibility is to express an opinion on these financial statements based on my audits.

I conducted my audit in accordance with generally accepted auditing standards. Those standards require that I plan and perform the audit to obtain reasonable assurance about whether the financial statements are free of material misstatement. An audit includes examining, on a test basis, evidence supporting the amounts and disclosures in the financial statements. An audit also includes assessing the accounting principles used and significant estimates made by management, as well as evaluating the overall financial statement presentation. I believe that my audit provides a reasonable basis for my opinion.

In my opinion, the financial statements referred to above present fairly, in all material respects, the financial position as of December 31, 2010 and 2009, the results of its operations and cash flows for the years then ended of **STEEL INTERTECH PUBLIC COMPANY LIMITED** in accordance with generally accepted accounting principles.

**S.K. ACCOUNTANT SERVICES COMPANY  
LIMITED**



**(Naris Saowalagsakul)**

**Authorized Auditor No. 5369**

Bangkok.

February 4, 2011

## STEEL INTERTECH PUBLIC COMPANY LIMITED

## BALANCE SHEETS

AS OF DECEMBER 31, 2010 AND 2009

		<b>2010</b>	<b>2009</b>
		<b>BAHT</b>	<b>BAHT</b>
<b>ASSETS</b>			
<b>CURRENT ASSETS</b>			
Cash and Cash Equivalents	(Note 5)	10,870,603.48	4,800,715.85
Accounts Receivable and Notes Receivable - Net	(Note 6)	31,803,022.94	37,685,485.47
Unbilled on Completed Works - Net	(Note 7)	10,625,245.03	20,009,938.34
Inventories - Net	(Note 8)	20,270,401.46	41,044,277.52
Others Current Assets		3,333,681.96	3,875,039.19
<b>TOTAL CURRENT ASSETS</b>		<b>76,902,954.87</b>	<b>107,415,456.37</b>
<b>NON - CURRENT ASSETS</b>			
Property, Plant and Equipment - Net	(Note 9)	81,057,195.02	80,811,263.73
Intangible Assets - Net	(Note 10)	349,555.33	479,747.33
Retention Account Receivable -Net	(Note 11)	4,830,638.44	3,335,581.43
<b>TOTAL NON - CURRENT ASSETS</b>		<b>86,237,388.79</b>	<b>84,626,592.49</b>
<b>TOTAL ASSETS</b>		<b>163,140,343.66</b>	<b>192,042,048.86</b>

Notes to financial statements are an integral part of these statements.

**STEEL INTERTECH PUBLIC COMPANY LIMITED**  
**BALANCE SHEETS**  
**AS OF DECEMBER 31, 2010 AND 2009**

	<b>2010</b>	<b>2009</b>
	<b>BAHT</b>	<b>BAHT</b>
<b>LIABILITIES AND SHAREHOLDERS' EQUITY</b>		
<b>CURRENT LIABILITIES</b>		
Short Term Loan from Financial Institution (Note 12 , 13)	-	10,000,000.00
Trade Accounts Payable	37,434,298.26	50,487,955.42
Current Portion of Long Term Loans (Note 12 , 14)	2,316,000.00	3,036,000.00
Current Portion of Liabilities Under Financial Lease Agreement (Note 15)	1,834,541.21	1,592,990.81
Other Current Liabilities		
Accrued Expenses	3,651,947.04	4,040,879.67
Dividend Payable	32,953.17	10,003,170.00
Over Collection by Completed Works (Note 7)	3,938,194.05	8,140,148.25
Cash Deposit for Goods	6,728,696.92	2,294,039.60
Others	4,435,029.67	3,342,963.79
<b>TOTAL CURRENT LIABILITIES</b>	<b>60,371,660.32</b>	<b>92,938,147.54</b>
<b>NON - CURRENT LIABILITIES</b>		
Long Term Loan from Financial Institution (Note 12 , 14)	5,287,681.35	10,803,681.35
Liabilities under Financial Lease Agreement - Net (Note 15)	4,339,638.95	1,632,271.23
<b>TOTAL NON - CURRENT LIABILITIES</b>	<b>9,627,320.30</b>	<b>12,435,952.58</b>
<b>TOTAL LIABILITIES</b>	<b>69,998,980.62</b>	<b>105,374,100.12</b>
<b>SHAREHOLDERS' EQUITY</b>		
Share Capital		
Authorized Share Capital: (Note 19)		
50,000,000 Ordinary Shares @ Baht 1.00	50,000,000.00	50,000,000.00
Issued and Paid-up Share Capital:		
50,000,000 Ordinary Shares @ Baht 1.00	50,000,000.00	50,000,000.00
Premium on Share Capital	25,870,200.00	25,870,200.00
Retained Earnings		
Appropriated		
Legal Reserve	5,415,157.44	5,415,157.44
Unappropriated	11,856,005.60	5,382,591.30
<b>TOTAL SHAREHOLDERS' EQUITY</b>	<b>93,141,363.04</b>	<b>86,667,948.74</b>
<b>TOTAL LIABILITIES AND SHAREHOLDERS' EQUITY</b>	<b>163,140,343.66</b>	<b>192,042,048.86</b>

Notes to financial statements are an integral part of these statements.

**STEEL INTERTECH PUBLIC COMPANY LIMITED**  
**STATEMENTS OF INCOME**  
**AS OF DECEMBER 31, 2010 AND 2009**

	<b>2010</b>	<b>2009</b>
	<b>BAHT</b>	<b>BAHT</b>
Revenue from Sales	145,105,141.58	148,316,246.21
Revenue from Sales and Installation	166,330,223.54	144,810,431.97
<b>TOTAL REVENUES</b>	<b>311,435,365.12</b>	<b>293,126,678.18</b>
Cost of Sales	(123,236,934.49)	(127,420,573.05)
Cost of Sales and Installation	(132,007,572.53)	(121,354,008.23)
<b>TOTAL COST</b>	<b>(255,244,507.02)</b>	<b>(248,774,581.28)</b>
<b>GROSS PROFIT</b>	<b>56,190,858.10</b>	<b>44,352,096.90</b>
Other Income	4,819,074.37	2,649,223.08
<b>PROFIT (LOSS) BEFORE EXPENSE</b>	<b>61,009,932.47</b>	<b>47,001,319.98</b>
Selling Expenses	(9,545,430.39)	(7,086,650.94)
Administrative Expenses	(26,750,736.27)	(22,042,636.66)
Management Remuneration (Note 16)	(10,727,100.61)	(10,858,978.20)
<b>TOTAL EXPENSES</b>	<b>(47,023,267.27)</b>	<b>(39,988,265.80)</b>
<b>PROFIT (LOSS) BEFORE COST OF FINANCIAL AND INCOME TAX</b>	<b>13,986,665.20</b>	<b>7,013,054.18</b>
Cost of Financial	(1,477,356.47)	(1,728,012.71)
<b>PROFIT (LOSS) BEFORE INCOME TAX</b>	<b>12,509,308.73</b>	<b>5,285,041.47</b>
Income Tax (Note 17)	(3,535,894.43)	(1,581,289.42)
<b>NET PROFIT (LOSS)</b>	<b>8,973,414.30</b>	<b>3,703,752.05</b>
BASIC EARNINGS(LOSS) PER SHARE (BAHT)	0.18	0.07
NUMBER OF ORDINARY SHARES (SHARES)	50,000,000.00	50,000,000.00

Notes to financial statements are an integral part of these statements.

**STEEL INTERTECH PUBLIC COMPANY LIMITED**  
**STATEMENTS OF CHANGES IN SHAREHOLDERS' EQUITY**  
**FOR THE YEAR ENDED ON DECEMBER 31, 2010 AND 2009**

		Issued and Paid - up Share Capital	Premium on Share Capital	Retained Earnings		Total
				Appropriated	Unappropriated	
		BAHT	BAHT	BAHT	BAHT	BAHT
<b>Balance as of December 31, 2009</b>		<b>50,000,000.00</b>	<b>25,870,200.00</b>	<b>5,415,157.44</b>	<b>5,382,591.30</b>	<b>86,667,948.74</b>
Dividend Payment	(Note 20)	-	-	-	(2,500,000.00)	(2,500,000.00)
Net Profit (Loss)		-	-	-	8,973,414.30	8,973,414.30
<b>Balance as of December 31, 2010</b>		<b>50,000,000.00</b>	<b>25,870,200.00</b>	<b>5,415,157.44</b>	<b>11,856,005.60</b>	<b>93,141,363.04</b>
<b>Balance as of December 31, 2008</b>		<b>50,000,000.00</b>	<b>25,870,200.00</b>	<b>5,415,157.44</b>	<b>20,176,619.25</b>	<b>101,461,976.69</b>
Dividend Payment	(Note 20)	-	-	-	(18,497,780.00)	(18,497,780.00)
Net Profit (Loss)		-	-	-	3,703,752.05	3,703,752.05
<b>Balance as of December 31, 2009</b>		<b>50,000,000.00</b>	<b>25,870,200.00</b>	<b>5,415,157.44</b>	<b>5,382,591.30</b>	<b>86,667,948.74</b>

Notes to financial statements are an integral part of these statements.

**STEEL INTERTECH PUBLIC COMPANY LIMITED**  
**CASH FLOW STATEMENTS**  
**FOR THE YEAR ENDED ON DECEMBER 31, 2010 AND 2009**

	<b>2010</b>	<b>2009</b>
	<b>BAHT</b>	<b>BAHT</b>
<b>CASH FLOW FROM OPERATING ACTIVITIES</b>		
Profit (Loss) Before Income Tax	12,509,308.73	5,285,041.47
Adjustment to net profit (loss) before corporate income tax for cash received (paid) from operations		
Doubtful Debts - Accounts Receivable and Notes Receivable	1,379,602.88	1,544,162.80
Doubtful Debts - Unbilled on Completed Works	926,242.88	-
Doubtful Debts - Other Accounts Receivable	-	150,181.91
Loss from Declining in Value of Inventories	-	101,484.89
Loss from Withholding Tax Unclaim	1,733,276.24	-
Depreciation	8,137,425.65	8,290,194.93
(Profit) Loss from Sales of Property, Plant and Equipment	(1,579,434.26)	(27,469.90)
Unrealized (Gain) Loss on Exchange Rate	-	(216,962.62)
Loss from Written off Assets	14,734.06	23,191.18
Amortized Expense of Intangible Assets	130,192.00	118,415.78
Interest Expenses	1,018,265.29	1,064,912.49
Amortized Interest Expenses of Financial Lease Agreement	362,303.54	298,750.24
Net Profit(Loss) from Operation before Changes in Operating Assets and Liabilities	24,631,917.01	16,631,903.17
(Increase)Decrease in Accounts Receivable and Notes Receivable	4,288,736.21	1,540,554.74
(Increase)Decrease in Unbilled on Completed Works	8,458,450.43	(12,850,947.28)
(Increase)Decrease in Inventories	20,773,876.06	6,181,604.85
(Increase)Decrease in Retention Account Receivable	(1,495,057.01)	(1,760,018.40)
(Increase)Decrease in Other Current Assets	(267,320.72)	1,858,549.35
Increase(Decrease) in Accounts Payable	(13,053,657.16)	(3,929,614.27)
Increase(Decrease) in Accrued Expenses	(388,932.63)	(467,833.63)
Increase(Decrease) in Over Collection by Completed Works	(4,201,954.20)	3,797,603.43
Increase(Decrease) in Other Current Liabilities	5,740,846.64	(2,239,893.06)
Cash Received (Paid) from Operating Activities	44,486,904.63	8,761,908.90
Cash Payment Corporate Income Tax and Withholding Tax	(4,460,492.72)	(4,161,135.27)
<b>NET CASH PROVIDED (USED) FROM OPERATING ACTIVITIES</b>	<b>40,026,411.91</b>	<b>4,600,773.63</b>
<b>CASH FLOW FROM INVESTING ACTIVITIES</b>		
Cash Received from Sales of Property, Plant and Equipment	1,579,439.26	27,529.40
Cash Payment for Purchase of Property, Plant and Equipment	(2,007,096.00)	(737,566.25)
Cash Payment for Intangible Assets	-	(85,700.00)
<b>NET CASH PROVIDED (USED) FROM INVESTING ACTIVITIES</b>	<b>(427,656.74)</b>	<b>(795,736.85)</b>

Notes to financial statements are an integral part of these statements.

**STEEL INTERTECH PUBLIC COMPANY LIMITED**  
**CASH FLOW STATEMENTS**  
**FOR THE YEAR ENDED ON DECEMBER 31, 2010 AND 2009**

	2010	2009
<b>CASH FLOW FROM FINANCING ACTIVITIES</b>		
Increase(Decrease) in Short - Term Loans from Financial Institute	(10,000,000.00)	2,000,000.00
Cash Payment for Long - Term Loans	(6,236,000.00)	(3,036,000.00)
Cash Payment for Liabilities Under Financial Lease Agreement	(3,804,385.42)	(1,673,643.83)
Cash Payment for Interest	(1,018,265.29)	(1,064,912.49)
Cash Payment for Dividends	(12,470,216.83)	(8,499,617.50)
<b>NET CASH PROVIDED (USED) FROM FINANCING ACTIVITIES</b>	<b>(33,528,867.54)</b>	<b>(12,274,173.82)</b>
<b>Cash and Cash Equivalent Items Increase(Decrease) - Net</b>	<b>6,069,887.63</b>	<b>(8,469,137.04)</b>
<b>Cash and Cash Equivalent Items at the Beginning of the Period</b>	<b>(Note 5) 4,800,715.85</b>	<b>13,269,852.89</b>
<b>Cash and Cash Equivalent Items at the Ending of the Period</b>	<b>(Note 5) 10,870,603.48</b>	<b>4,800,715.85</b>
<b>Additional Disclosure of Cash Flow:</b>		
1. Non-cash Transactions		
1.1 The Company Purchased Vehicle under Financial Lease Agreement	6,391,000.00	-
1.2 Allowance for Doubtful Accounts (Increase) Decrease from Output Tax Suspense	(214,123.44)	55,944.86
1.3 Property, Plant and Equipment Increase by transfer from Inventories	-	18,224.20

Notes to financial statements are an integral part of these statements.

**STEEL INTERTECH PUBLIC COMPANY LIMITED**

**NOTE TO FINANCIAL STATEMENTS**

**DECEMBER 31, 2010 AND 2009**

**1. General Information**

The Company was registered on August 6,1993, registration number (3)215/2536 and later registered as a public company on March 16,2005, registration number 0107574800137 with its registered head office located at 8/88 Moo 12, Rachathewa, Bangplee, Samutprakran and branch office is located at 8 Moo 15, Bangpleeyhai, Bangplee, Samutprakarn. The Company has Aunwarawong's Family by the major shareholder in the rate shareholder of 46% of share capital.

The Company operates main business in relation to sales of construction material, production of roof sheet and service rendered of installation of roof sheets.

**2. The Basis of Preparation of the Financial Statements**

- 2.1 The Company had prepared the financial statements have been prepared in accordance with the accounting standards enunciated under the Accounting Profession Act B.E. 2547. The presentation of the financial statements has been made in accordance with Accounting Standards TAS 1 (Revised 2007) "Presentation of financial statements" and in accordance with the determination of the office of the Securities and Exchange Commission on the subject of preparation and presentation of the financial reports.
- 2.2 The financial statements are prepared on the historical cost basis except as disclosed in the accounting policies.
- 2.3 In order to prepare the financial statements to comply with generally accepted accounting standards, the company's management had to make some estimates and suppositions which may have an effect on the amount shown for revenue, expenses, assets and liabilities and also on the disclosures concerning assets and contingent liabilities, therefore the actual result may differ the estimated amount.
- 2.4 For the convenience of the user, and English translation of the financial statements has been prepared from the financial statements that are issued in the Thai language.

2.5 For the year ended on December 31, 2009, the financial statements as presented herein for comparative purpose have been reclassified to conform with the current period's classifications with no effect on the net profit (loss) or shareholder's equity as previously reported as follow :

		Amount <u>'000 Baht</u>
Current Liabilities	Decrease	(1,493)
Non - Current Assets	Increase	1,493

### 3. Announcement for Adoption of Accounting Standards, Financial Reporting Standard and New International Financial Reporting Interpretations.

The Federation of Accounting Professions has issued Notification No. 17/2553 and No. 50- 54/2553, regarding to accounting standards, financial reporting standards and international financial reporting interpretations. These are not effective for the current year, except Framework for the Preparation and Presentation of Financial Statements, which is immediately effective.

		<u>Effective date</u>
Framework (revised 2009)		Immediately
TAS 1 (revised 2009)	Presentation of Financial Statements	1 January 2011
TAS 2 (revised 2009)	Inventories	1 January 2011
TAS 7 (revised 2009)	Statement of Cash Flows	1 January 2011
TAS 8 (revised 2009)	Accounting Policies, Changes in Accounting Estimates and Errors	1 January 2011
TAS 10 (revised 2009)	Events After the Reporting Period	1 January 2011
TAS 11 (revised 2009)	Construction Contracts	1 January 2011
TAS 12	Income Taxes	1 January 2013
TAS 16 (revised 2009)	Property Plant and Equipment	1 January 2011
TAS 17 (revised 2009)	Leases	1 January 2011
TAS 18 (revised 2009)	Revenue	1 January 2011
TAS 19	Employee Benefits	1 January 2011
TAS 20 (revised 2009)	Accounting for Government Grants and Disclosure of Government Assistance	1 January 2013
TAS 21 (revised 2009)	The Effects of Changes in Foreign Exchange Rate	1 January 2013
TAS 23 (revised 2009)	Borrowing Costs	1 January 2011
TAS 24 (revised 2009)	Related Party Disclosures	1 January 2011
TAS 26	Accounting and Reporting by Retirement Benefit Plans	1 January 2011
TAS 27 (revised 2009)	Consolidated and Separate Financial Statements	1 January 2011
TAS 28 (revised 2009)	Investments in Associates	1 January 2011
TAS 29	Financial Reporting in Hyperinflationary Economies	1 January 2011

		<u>Effective date</u>
TAS 31 (revised 2009)	Interests in Joint Venture	1 January 2011
TAS 33 (revised 2009)	Earnings per Share	1 January 2011
TAS 34 (revised 2009)	Interim Financial Reporting	1 January 2011
TAS 36 (revised 2009)	Impairment of Assets	1 January 2011
TAS 37 (revised 2009)	Provisions, Contingent Liabilities and Contingent Assets	1 January 2011
TAS 38 (revised 2009)	Intangible Assets	1 January 2011
TAS 40 (revised 2009)	Investment Property	1 January 2011
TFRS 2	Share - Based Payment	1 January 2011
TFRS 3 (revised 2009)	Business Combination	1 January 2011
TFRS 5 (revised 2009)	Non-current Assets Held for Sale and Discontinued Operations	1 January 2011
TFRS 6	Exploration for and Evaluation of Mineral Resources	1 January 2011
IFRIC 15	Agreements for the Construction of Real Estate	1 January 2011

The management of the Company has assessed the effect of the accounting standards and the financial reporting standard believes that these standards will not have any significant impact on the financial statements for the year in which they are initially applied. Except, the TAS 19 Employee Benefits, the management of the Company has been evaluating for the contingent liabilities from Retirement Benefit Plans.

#### **4. Summary of Significant Accounting Policy**

##### **4.1 Revenues Recognition**

- Sales revenue is recognized when goods have been delivered to customer.
- Revenue from sales and installation is recognized in accordance with the percentage of completion method which is computed in accordance with the ratio of actual cost of sale and installation services rendered over the entire cost which is estimated to use in the sale and installation services rendered.
- Revenue of interest receivable is recognized in accordance with the portion of period which is computed from outstanding principle.

##### **4.2 Expenses Recognition**

- Expenses are recognized on accrual basis.

##### **4.3 Cash and Cash Equivalent**

Cash and equivalent items are included cash at bank in saving accounts, current accounts and fixed accounts not over than 3 months and free from any guarantees.

#### 4.4 Trade Account Receivable, Other Account Receivable and Allowance for Doubtful Debt

Trade account receivable and other account receivable are reflected by net realizable value. The Company records allowance for doubtful debt for loss result by estimating the contingent amount from non-collection from accounts receivable while it is generally considered from experience of collection, aging analysis and status review of accrued accounts receivable as of the date in the balance sheet.

#### 4.5 Inventories

Inventories are valued at cost under FIFO method or net realizable value whichever is lower.

#### 4.6 Borrowing Costs

Interest expense which incurred from loan so as for use in the construction of building, procurement of machinery and equipment is recorded as part of asset cost and will cease the record of interest to be asset cost when the construction or installation is completed.

#### 4.7 Property, Plant and Equipment

Property, plant and equipment are recorded at cost on the transaction date after deduction of depreciation expenses which are calculated on a straight-line method over their approximate useful-life as follows:

Building	20 Years
Machinery	5 , 10 Years
Mould	5 Years
Tools and Equipment	5 Years
Furniture and Fixture	5 Years
Office Equipment	5 Years
Computer and Computer Equipment	5 Years

No depreciation is provided to land and assets under construction.

Expenditure in respect of improvement, life renewal or asset improvement which causes the present replacement cost of asset increased materially will be included as cost of asset. For repairable and maintenance is recognized as expense in the incurred accounting period.

Gain or loss from disposal of property, plant and equipment is computed from discrepancy between net cash received and book value and recognized as other revenue or other expense in the statement of income.

#### 4.8 Intangible Asset

Intangible Asset, type of computer software is valued at cost on the transaction date deducted accumulated amortization; amortization is calculated by reference to its cost on a straight line method over the 5 years useful life.

#### 4.9 Impairment

The carrying amounts of the Company's assets are reviewed at each balance sheet date to determine whether there is any indication of impairment. If any such indication exists, the asset's recoverable amount is estimated. Impairment with cost, if assets exceed its recoverable amount, the Company will recognize an impairment loss in the statement of income.

##### Calculation of recoverable amount

- The recoverable amount is the greater of the asset's net selling price and value in use. In assessing value in use, the estimated future cash flows are discounted to their present value using a pre-tax discount rate that reflects current market assessments of the time value of money and the risks specific to the asset. For an asset that does not generate cash inflows largely independent of those from other assets, the recoverable amount is determined for the cash-generating unit to which the asset belongs.

##### Reversals of impairment

- An impairment loss is reversed if there has been a change in the estimates used to determine the recoverable amount. An impairment loss is reversed only to the extent that the asset's carrying amount does not exceed the carrying amount that would have been determined, net of depreciation or amortization, if no impairment loss had been recognized. All reversals of impairment losses are recognized in the statement of income.

#### 4.10 Provisions

Provision are recognized when the Company has a present legal or constructive obligation as a result of past events, it is probable that an outflow of resources will be required to settle the obligation, and a reliable estimate of the amount can be made. Where the Company expects a provision to be reimbursed, the reimbursement is recognized as a separate asset but only when the reimbursement is virtually certain.

#### 4.11 Financial Leased Contract

Where the Company is the lessee

The contract of leased asset carried the risk and owner remuneration is mainly transferred to lessee will be classified as financial leased contract. The contract of financial lease is recorded as capital expenditure by fair value of leased asset or present value of minimum amount which has to repay in accordance with the leased contract whichever amount is lower. The amount which has to repay in each time will be divided as liability portion and financial expense so that fixed interest rate over outstanding accrued liability of obligation commitment according to the financial lease contract will be recorded as long term liability. Interest payable will be recorded in the statement of income throughout the leased contract life. Asset which acquired by financial leased contract will be depreciated in accordance with the estimated useful life of those assets.

#### 4.12 Employees benefit

The company is recognized salary, wage, bonus, social security fund, staff provident fund and other staff welfare are expense on date the transactions occur.

#### 4.13 Items Denominated in Foreign Currencies

Items denominated in foreign currencies are recorded in Baht at the prevailing exchange rate when the transactions occur, and their balances of assets and liabilities at the ended of period are converted into Baht at the prevailing exchange rate on that date. Profit or loss arising from such conversion is shown as revenues or expenses in the income statements.

#### 4.14 Financial Instruments

Financial instruments, financial assets were shown in balance sheets composed of cash and cash at banks, accounts receivable. Financial liabilities were shown in balance sheets composed of accounts payable and borrowings. The accounting policy of each item would be disclosed in separated items.

#### 4.15 Basic Earning (Loss) per Share

Basic earning (loss) per share is calculated by dividing net profit (loss) with the number of issued and paid-up shares at the end of the period. The company did not calculate the fully diluted earnings (loss) per share since it has no ordinary share equivalent.

**5. Cash and Its Equivalent Item**

Consists of:

	As of December 31, 2010 Baht	As of December 31, 2009 Baht
Cash	40,000.00	40,000.00
Bank Deposit – Current Accounts	5,680,381.09	3,306,036.35
Bank Deposit – Saving Accounts	5,150,222.39	1,454,679.50
Total	<u>10,870,603.48</u>	<u>4,800,715.85</u>

**6. Accounts Receivable and Notes Receivable - Net**

Consists of:

	As of December 31, 2010 Baht	As of December 31, 2009 Baht
Post Date Cheque	7,166,465.36	4,826,822.00
Return Cheque	7,707,697.16	11,555,437.36
Accounts Receivable		
Within due period	9,495,913.15	7,391,590.63
Over 1 – 30 Days	11,338,630.75	13,788,818.30
Over 31 – 60 Days	691,448.20	1,587,384.52
Over 61 – 120 Days	423,410.93	3,259,437.44
Over 121 – 180 Days	158,935.65	844,524.30
Over 180 Days	9,524,256.85	7,541,479.71
Total	<u>46,506,758.05</u>	<u>50,795,494.26</u>
<u>Less</u> Allowance for Doubtful Debt	<u>(14,703,735.11)</u>	<u>(13,110,008.79)</u>
Net	<u>31,803,022.94</u>	<u>37,685,485.47</u>

For the year end on December 31, 2010 and 2009, the movement of allowance for doubtful accounts was as follows:

	For the year end on	
	December 31, 2010	December 31, 2009
	Baht	Baht
Allowance for Doubtful Debt was movement transaction		
Beginning	(13,110,008.79)	(11,621,790.85)
<u>Add</u> Increase during periods	(2,350,623.88)	(2,047,385.24)
<u>Less</u> Reversed From Cash Receiving	756,897.56	559,167.30
Ending	<u>(14,703,735.11)</u>	<u>(13,110,008.79)</u>

#### 7. Unbilled on Completed Works and Over Collection by Completed Works

Consists of:

	As of December 31,	As of December 31,
	2010	2009
	Baht	Baht
Contract Value	<u>296,292,986.02</u>	<u>271,691,681.18</u>
Cost of Sales and Installation until Current Period	221,627,348.81	180,279,434.56
Recognition of Profit(Loss) until Current Period	<u>47,784,828.29</u>	<u>17,514,183.98</u>
Cost of Sales and Installation and Recognition of Profit(Loss)	269,412,177.10	197,793,618.54
<u>Less</u> Progress billings	<u>(261,798,883.24)</u>	<u>(185,923,828.45)</u>
Net	<u>7,613,293.86</u>	<u>11,869,790.09</u>
Unbilled on Completed Works	11,551,487.91	20,009,938.34
Over Collection by Completed Works	(3,938,194.05)	(8,140,148.25)

As of December 31, 2010 and 2009, unbilled on completed works and over collection by completed works, consists of:

	As of December 31,	As of December 31,
	2010	2009
	Baht	Baht
Unbilled on Completed Works and Over Collection	11,551,487.91	20,009,938.34

<u>Less</u> Allowance for Doubtful Debt	(926,242.88)	-
Net	<u>10,625,245.03</u>	<u>20,009,938.34</u>

For the year end on December 31, 2010 and 2009, the movement of allowance for doubtful accounts was as follows:

	For the year end on	
	December 31, 2010	December 31, 2009
	Baht	Baht
Allowance for Doubtful Debt was movement transaction		
Beginning	-	-
<u>Add</u> Increase during periods	(926,242.88)	-
<u>Less</u> Reversed From Cash Receiving	-	-
Ending	<u>(926,242.88)</u>	<u>-</u>

## 8. Inventories - Net

Consists of:

	As of	As of
	December 31, 2010	December 31, 2009
	Baht	Baht
Finished Goods	1,786,777.54	3,721,354.93
Works in Process	2,312,638.88	3,202,449.00
Raw Materials	16,745,012.63	32,629,746.67
Supplies	580,886.42	408,925.06
Goods in transit	-	2,236,715.87
Total	<u>21,425,315.47</u>	<u>42,199,191.53</u>
<u>Less</u> Allowance for Declining in Value of Inventories	<u>(1,154,914.01)</u>	<u>(1,154,914.01)</u>
Total	<u>20,270,401.46</u>	<u>41,044,277.52</u>

For the year end on December 31, 2010 and 2009, Allowance for declining in value of inventories was movement transaction as follow:

	For the year end on	
	December 31, 2010	December 31, 2010
	Baht	Baht
Beginning	(1,154,914.01)	(1,053,429.12)
<u>Add</u> Increase during periods	-	(101,484.89)
<u>Less</u> Transfer out/Sales	-	-
Ending	<u>(1,154,914.01)</u>	<u>(1,154,914.01)</u>

As of December 31, 2010 and 2009, the Company has insured against fire insurance of finished goods, raw material and supplies carried insurance amount of Baht 6.80 million whereby beneficiaries from insurance is granted to one merchant bank in accordance with note no. 12.

## 9. Property, Plant and Equipment – Net

Consists of:

	Balance As of January 1,2010 Baht	Increase/ Transfer in Baht	Sale/ Transfer out Baht	Balance As of December 31,2010 Baht
<b>Cost :</b>				
Land and Land Improvements	36,103,655.79	-	-	36,103,655.79
Factory Building	34,765,709.53	-	-	34,765,709.53
Building Improvements – Factory	4,353,738.78	21,200.00	-	4,374,938.78
Machineries	17,069,238.14	492,000.00	(200,000.00)	17,361,238.14
Mould	4,898,820.84	60,000.00	-	4,958,820.84
Tools and Equipment	3,950,415.57	88,620.00	(4,620.00)	4,034,415.57
Vehicles	11,432,769.69	7,417,168.22	(3,626,873.81)	15,223,064.10
Office Equipment	4,094,430.39	122,053.27	(56,111.22)	4,160,372.44
Furniture and Fixtures	948,822.16	-	-	948,822.16
Computer and Computer Equipment	1,916,446.16	171,415.51	(69,914.49)	2,017,947.18
Work in Installation	-	25,639.00	-	25,639.00
<b>Total Cost</b>	<b>119,534,047.05</b>	<b>8,398,096.00</b>	<b>(3,957,519.52)</b>	<b>123,974,623.53</b>
<b>Accumulated Depreciation :</b>				
Factory Building	(7,477,085.21)	(1,738,285.44)	-	(9,215,370.65)
Building Improvements – Factory	(2,351,084.18)	(679,349.66)	-	(3,030,433.84)
Machineries	(11,097,402.73)	(888,653.95)	199,999.00	(11,786,057.68)
Mould	(3,218,545.27)	(875,975.01)	-	(4,094,520.28)
Tools and Equipment	(2,835,482.89)	(487,456.89)	2,594.14	(3,320,345.64)
Vehicles	(7,511,718.32)	(2,443,324.52)	3,626,869.81	(6,328,173.03)

Office Equipment	(2,397,104.69)	(645,476.38)	44,067.39	(2,998,513.68)
Furniture and Fixtures	(504,794.07)	(150,238.89)	-	(655,032.96)
Computer and Computer Equipment	(1,329,565.96)	(228,664.91)	69,250.12	(1,488,980.75)
<b>Total Accumulated Depreciation</b>	<b>(38,722,783.32)</b>	<b>(8,137,425.65)</b>	<b>3,942,780.46</b>	<b>(42,917,428.51)</b>
<b>Net</b>	<b>80,811,263.73</b>			<b>81,057,195.02</b>

## Depreciation for the year

Ended on December 31,

2010	8,137,425.65
2009	8,290,194.93

As of December 31, 2010, a part of vehicles in book value amount of Baht 6.59 million (As of December 31, 2009, in amount of Baht 3.02 million), occurrence from financial lease agreement in accordance with note no. 15.

As of December 31, 2010, the Company pledged land, property plus existing and contingent construction was mortgaged in book value amount of Baht 61.53 million (As of December 31, 2009 in amount of Baht 63.27 million), guaranteed against loan due to one merchant bank. In addition, the beneficiary from insurance for the property in the amount according to the insurance contract in amount of Baht 34.20 million is granted to such commercial bank according with note no. 12.

As of December 31, 2010, the Company had assets with the depreciation fully calculated but still in use which had a cost value of Baht 14.87 million which have book value in amount of Baht 438. (As of December 31, 2009: cost value of Baht 12.92 million which have book value in amount of Baht 285).

**10. Intangible Assets -Net**

Consists of:

	Balance As of January 1,2010 Baht	Increase/ Transfer in Baht	Sale/ Transfer out Baht	Balance As of December 31,2010 Baht
<b>Cost :</b>				
Computer Software	650,960.00	-	-	650,960.00
<b>Total Cost</b>	<b>650,960.00</b>	-	-	<b>650,960.00</b>
<b>Accumulated Amortization</b>				
Computer Software	(171,212.67)	(130,192.00)	-	(301,404.67)
<b>Total Accumulated Amortization</b>	<b>(171,212.67)</b>	<b>(130,192.00)</b>	-	<b>(301,404.67)</b>
<b>Net</b>	<b>479,747.33</b>			<b>349,555.33</b>
Amortization for the year				
Ended on December 31,				
2010				130,192.00
2009				118,415.78

**11. Retention Account Receivable - Net**

Consists of :

	As of December 31, 2010 Baht	As of December 31, 2009 Baht
Retention Account Receivable	5,017,756.84	3,522,699.83
<u>Less</u> Allowance for Doubtful Accounts	(187,118.40)	(187,118.40)
Retention Account Receivable - Net	<u>4,830,638.44</u>	<u>3,335,581.43</u>

**12. Credit Facility which Received from Merchant Bank**

As of December 31, 2010, the Company received credit facility from merchant bank in form of bank overdrawn account, short term loan, letter of guarantee, long term loan and letter of credit in amount of Baht 101.00 million (December 31, 2009: in amount of Baht 101.00 million) while land plus property, beneficiaries from fired insurance in building, machinery and inventory are collateral.

**13. Short-term Loans from Financial Institutions**

As of December 31, 2009, the whole amount of short term loan from a commercial bank is derived from taking promissory note for 90 days, interest rate MLR-1.50% equivalent to 4.35% per annum and have pledged as according with note no. 12.

**14. Long Term Loan from Financial Institution - Net**

Consists of:

	As of December 31, 2010 Baht	As of December 31, 2009 Baht
Long Term Loans	7,603,681.35	13,839,681.35
<u>Less</u> Current Portion of Long Term Loans	<u>(2,316,000.00)</u>	<u>(3,036,000.00)</u>
Net	<u>5,287,681.35</u>	<u>10,803,681.35</u>

As of December 31, 2010 and 2009, the whole amount is long term loan due to one merchant bank to construct and decorate the office building in the loan total credit line of Baht 20 million. It is reimbursed as installment and had been repay balance by amount of Baht 7.60 million and Baht 13.84 million, respectively. Interest is carried by the year 1<sup>st</sup>-2<sup>nd</sup> equivalent MLR-1.25% per annum and from year 3<sup>rd</sup> until debt will be completely repayable equivalent MLR per annum. The Company pledged land, building plus property existed and contingent in the future, and inventory including given the beneficiary from insurance for collateral, are determined to be repayable as follow;

- For the loan credit line of Baht 15 million, the principle is determined to be repayable in 78 months by Baht 0.19 million per month. The first installment will commence to repay on January 31, 2008 and following installments are repayable on the final business day of the month.
- For the loan credit line of Baht 5 million, the principle is determined to be repayable in 78 months by Baht 0.06 million per month. The first installment will commence to repay on July 31, 2008 and following installments are repayable on the final business day of the month. For the September 2010, the Company had been repaying in the whole amount of the loan credit line of Baht 5 million.

**15. Liabilities under Financial Lease Agreement - Net**

Consists of :

	As of December 31, 2010 Baht	As of December 31, 2009 Baht
Liabilities under financial lease agreement	6,726,034.03	3,549,352.09
<u>Less</u> Deferred interest	(551,853.87)	(324,090.05)
Net	<u>6,174,180.16</u>	<u>3,225,262.04</u>
Due for Payment of financial lease agreement as follow :		
Portion to Payment within 1 year	1,834,541.21	1,592,990.81
Portion to Payment after 1 year but within 4 years	4,339,638.95	1,632,271.23
Net	<u>6,174,180.16</u>	<u>3,225,262.04</u>

As of December 31, 2010 and 2009, the Company performs the contract of long term financial leased with several leasing companies so as to lease motor vehicle. The leased contracts determine leased fee repayment as monthly installment from Baht 17,227.00 per month to Baht 51,149.00 per month. The leased period is carried from 2-4 years. In addition, ownership of such motor vehicle will transfer to ownership of the Company when pays the final installment in accordance with the leased contract or pays for bargain purchase option when the end of the leased contract.

**16. Management Remuneration**

This management remuneration is contributed to the management of the Company and directors of the Company. It is composed of remuneration that is monetary, i.e. salaries, related fringe benefit and director's remuneration including remuneration in other form. The Company's management is the persons who are defined under the Securities and Exchange Act.

**17. Corporate Income Tax**

For the year ended of December 31, 2010 and 2009, the company calculated the income tax at the rate of 20% which is complied which the basis in the Act in accordance with the Decree no.387, which amended the rate of the corporate income tax expense from 30% to 20% for the five consecutive accounting periods from the initial accounting period or after the date a public company is listed on the Stock Exchange MAI (Market for Alternative Investment) (as of November 30, 2005) in accordance with the law on Securities and Stock Market. The company computed corporate income tax of accounting net

profit after adding adjusted transaction in accordance with the Revenue Code which is mainly doubtful debt transaction and depreciation exceeding the rate determined in the Revenue Code.

## 18. Expenses by Nature

Some expenses which included in calculation of profit (loss) from operation are able to analyses by nature as follows.

	For the year end on December 31,	
	2010	2009
	Baht	Baht
Changing within Work in Process and Finish Goods	2,824,387.51	(3,879,839.43)
Raw Material, Finished Goods and Supplies Used	202,533,282.26	206,062,984.43
Cost of Installation	31,745,993.01	31,665,727.54
Loss From Declining in Value of Inventories	-	101,484.89
Employees Expense	29,919,709.14	27,661,799.63
Depreciation and Amortization	8,267,617.65	8,408,610.71
Doubtful Debts	2,305,845.76	1,694,344.71
Other Expenses	24,670,938.96	17,047,734.60
Total	302,267,774.29	288,762,847.08

## 19. Share Capital

Authorized share capital, issued and paid-up share capital have movement as follows:

	Par Value	As of December 31, 2010		As December 31, 2009	
		Share	Share	Value	Value
	(Baht)	('000 Share)	('000 Share)	('000 Baht)	('000 Baht)
<b>Authorized Share Capital</b>					
Beginning Ordinary Share	1.00	50,000	50,000	50,000	50,000
<u>Less</u> Decrease Ordinary Share	-	-	-	-	-
<u>Add</u> Increase Ordinary Shares	1.00	450,000	450,000	-	-
Ending ordinary Shares	1.00	500,000	500,000	50,000	50,000
<b>Issued and Paid-up Share Capital</b>					
Beginning Ordinary Share	1.00	50,000	50,000	50,000	50,000
<u>Less</u> Decrease Ordinary Share	-	-	-	-	-
<u>Add</u> Increase Ordinary Shares	-	-	-	-	-
Ending ordinary Shares	1.00	50,000	50,000	50,000	50,000

In accordance with the minute of extra-ordinary shareholders meeting no. 2/2010 held on October 6, 2010, it is unanimously resolved to registered share capital is increased by another Baht 450.00 million. The company has increased the registered share capital for the former 50.00 million shares in par value of Baht 1.00 per share totaling Baht 50.00 million to the registered share capital for 500.00 million shares in par value of Baht 1.00 per share totaling Baht 500.00 million. The Company has already registered the increased share capital at the Ministry of Commerce.

## **20. Dividend Payment and Legal Reserve**

- 20.1 In accordance with the resolution of the Board of Directors' Meeting no.3/2010 held on May 13, 2010, It is unanimously resolved to appropriated retained earnings for dividend to shareholder of Baht 0.05 per share and totaling Baht 2.50 million, while it is determined to repay on June 11, 2010. Present, the Company has already paid the dividend to shareholder.
- 20.2 In accordance with the resolution of the Board of Directors' Meeting No.5/2009 held on December 23, 2009, it was unanimously resolved to appropriated retained earnings for dividend to shareholder of Baht 0.20 per share and totaling Baht 9.99 million. Dividend payment to be made on January 22, 2010, Present, the Company has already paid the dividend to shareholder.
- 20.3 In accordance with the resolution of the Board of Directors' Meeting No.3/2009 held on August 11, 2009, it was unanimously resolved to appropriated retained earnings for dividend to shareholder of Baht 0.05 per share and totaling Baht 2.50 million. Dividend payment to be made on September 10, 2009, Present, the Company has already paid the dividend to shareholder.
- 20.4 In accordance with the resolution of the shareholders meeting for year 2009 held on April 21, 2009, It is unanimously resolved dividend repayment for year 2008 to shareholders in the rate of Baht 0.27 per share. The board of directors of the Company approved the interim dividend repayment in this accounting period year 2008 in total of Baht 0.15 per share. There is outstanding dividend payable in the rate of Baht 0.12 per share in total amount of Baht 6.00 million while it is determined to repay on May 14, 2009. Present, the Company has already paid the dividend to shareholder.

## **21. Segment Financial Information**

The Company operates main business in relation to sales of construction material, production of roof sheet and service rendered of installation of roof sheets and operates in one geographical sector, i.e. Thailand. As a result, the total revenue, profit and asset which are reflected in the financial statements will be related to business sector and geographical sector in accordance with those mentioned.

## 22. Financial Instruments

### 22.1 Policy on Financial Risk Management

The company has no policy to hold or issue financial instruments for speculating or trading.

### 22.2 Risks on Interest Rates

Risk on interest rates is derived from fluctuation of market interest rate in the future which affect upon operation result and cash flow. The company had assets and liabilities which it may have risk on interest rate as follows:

	Amount		Annual Interest Rate	
	December 31,2010	December 31,2009	December 31,2010	December 31,2009
	<u>Million Baht</u>	<u>Million Baht</u>	<u>%</u>	<u>%</u>
Bank Deposit – Saving Accounts	5.15	1.45	0.25-0.50	0.50
Short Term Loans from Commercial Bank	-	10.00	-	4.35
Long-Term Loans from Commercial Bank	7.60	13.84	MLR	MLR and MLR-1.25%

### 22.3 Foreign Currency Risk

The Company has not foreign currency risk due to the Company has not commercially all assets and liabilities in foreign currencies.

### 22.4 Credit Term Risk

The Company constitutes risk from credit provision in respect of trading account receivable since debtor may not be able to repay debt in accordance with the term and covenant which agreed; as a result, it may cause financial damage. However, the Company has determined policy to hedge against such risk by analysis of financial status and consideration of ability in debt repayment of each customer in the consideration of credit provision. Moreover, the Company determines that customers have to repay some portion of deposit in advance before sale. For account receivable that is anticipated of uncollectible, the Company has considered to setup allowance for doubtful debt sufficiently.

### 22.5 Fair Value

According to most of company's financial asset and financial liabilities are short term nature and loan from Bank have interest at market rate. The company management believes that the book value of financial asset and financial liabilities are shown no significantly different from the fair value.

### 23. Contingent Liabilities and Obligations

- 23.1 The Company constitutes commitment obligation in the warranty of product quality and installation service to the Company customers under the term that such damage has to incur directly from product material which does not include damage which incur from outside other performance that cause damage to product. The period of warranty is approximately 1 year – 20 years. However, the Company management believes that the Company does not constitute materially contingent liability from such warranty since the Company products distributors constitute warranty of product quality under the same term and covenant, carried the period of warranty of 5-30 years. Therefore, the Company will not recognize expense and contingent liability from such warranty included in these financial statements.
- 23.2 Apart from liability which is reflected in the financial statements, the Company constitutes contingent liability as follows:

	As of December 31, 2010	As of December 31, 2009
	Baht	Baht
Letters of Guarantee – Banks	1,151,633.41	4,749,005.42
Letter of Credit - Credit limited Baht 25.00 million	-	1,054,539.08

- 23.3 The Company constitutes obligation commitment from the performance of installation contractor contract for the project of sale plus installation as of December 31, 2010, the Company constitutes the obligation commitment that has to repay installation contractor by amount of Baht 3.64 million (As of December 31, 2009, in amount of Baht 8.91 million). However, the Company constitutes the revenue from sales plus installation according to the unearned contract by amount of Baht 26.95 million (As of December 31, 2009, in amount of Baht 61.40 million).

### 24. Provident Fund

The Company and its employees have participated in registered AIA Munkong Provident Fund under the Provident Fund Act B.E. 2530. The fund is contributed to by both employees and the Company. This provident fund is managed by American International Insurance Public Company Limited and will be paid to the employees upon termination in accordance with the rules of the fund. For the years ended on December 31, 2010, the Company has repaid staff provident fund by amount of Baht 0.60 million (on December 31, 2009: Baht 0.62 million).

**25. Other**

- 25.1 In accordance with the minute of the board of directors meeting no. 2/2010 held on March 23, 2010, it unanimously resolves to approve ordinary shares acquisition of the Solar Power Co., Ltd., from shareholders of the Solar Power Co., Ltd. The Company will enter to purchase such shares in number of 35.00 million shares in value of Baht 10.00 per share by amount of Baht 350.00 million, equivalent to 100% of ordinary shares of the Solar Power Co., Ltd., which the Company will repay such shares acquisition fee by issuing newly ordinary shares of the Company in number of 350.00 million shares in value of Baht1.00 per share in the offering price of Baht1.00 per share aggregating to amount of Baht 350.00 million in order to remunerate to shareholders of the Solar Power Co., Ltd., instead of repayment in cash. However, proportion of shares exchange equivalent to 1 share of the Solar Power Co., Ltd., over 10 new shares of the Company (Share Swap). The Company has been approved by the extra-ordinary shareholders meeting no. 1/2010 held on May 13, 2010.
- 25.2 In accordance with the resolution of the Board of Directors' Meeting no.4/2010 held on August 4, 2010 and the minute of the extra-ordinary shareholders meeting no. 2/2010 held on October 6, 2010, it unanimously resolves to
- 25.2.1 Cancellation of the resolution of the Board of Directors' Meeting no.2/2010 held on March 23, 2010, regarding the acquisition of ordinary shares in Solar Power Co., Ltd., from shareholders of the Solar Power Co., Ltd. Because the Solar Power Co., Ltd, it is unanimously resolved to registered share capital is increased for the former 35.00 million shares in par value of Baht 10.00 per share totaling Baht 350.00 million to the registered share capital for 45.00 million shares in par value of Baht 1.00 per share totaling Baht 450.00 million.
- 25.2.2 Approve ordinary shares acquisition of the Solar Power Co., Ltd., from shareholders of the Solar Power Co., Ltd. The Company will enter to purchase such shares in number of 45.00 million shares in value of Baht 10.00 per share by amount of Baht 450.00 million, equivalent to 100% of ordinary shares of the Solar Power Co., Ltd., which the Company will repay such shares acquisition fee by issuing newly ordinary shares of the Company in number of 450.00 million shares in value of Baht1.00 per share in the offering price of Baht1.00 per share aggregating to amount of Baht 450.00 million in order to remunerate to shareholders of the Solar Power Co., Ltd., instead of repayment in cash. However, proportion of shares exchange equivalent to 1 share of the Solar Power Co., Ltd., over 10 new shares of the Company (Share Swap).

25.2.3 And it is unanimously resolved to registered share capital is decreased by 350.00 share million in par value of Baht 1.00 per share totaling Baht 350.00 million which for cancelling the registered share capital but unissued ordinary shares and it is unanimously resolved to increased the registered share capital for Baht 450.00 million. The company has increased the registered share capital for the former 50.00 million shares in par value of Baht 1.00 per share totaling Baht 50.00 million to the registered share capital for 500.00 million shares in par value of Baht 1.00 per share totaling Baht 500.00 million. Presently, the Company in during to take action for registered by the Ministry of Commerce.

## **26. Capital Management**

The objectives of the Company's capital management are to maintain their abilities to continue as a going concern and to maintain an appropriate capital structure and to maintain the ratio of debt to equity not excess as required by loan contract.

As at December 31, 2010 and 2009, debt to equity ratio in the financial statements is 0.75 : 1 and 1.22 : 1, respectively.

## **27. Approval of the Financial Statements**

These financial statements have been approved to issue by the authorized director on February 4, 2011.

---

